

# SP PRO ABB UNO Managed AC Coupling Installation Notes



## SP PRO ABB UNO Managed AC Coupling

### Introduction

The SP PRO Managed AC Coupling provides a method of linking the ABB UNO Selectronic Certified (SCERT) inverters to the SP PRO via the AC Load supply so that regardless of whether the grid or a generator is connected, the SP PRO can manage and control the ABB UNO string inverters.

Each SP PRO can manage a maximum of five ABB UNO inverters by commanding each inverter to output the right amount of power that is needed simultaneously to supply the load, export any excess and maintain the battery bank at any particular point in time. This is done via a communications link which also serves to retrieve all the operational data for display and logging by the SP PRO.

**Note:** This document needs to be read in conjunction with the SP PRO Instruction Manual and any relevant ABB UNO Instruction Manuals.

| Applicable ABB UNO models   | Wireless Kit                     | Suitable System Application |         |
|---|----------------------------------|-----------------------------|---------|
|   |                                  | Off Grid                    | On Grid |
| Order<br>ABB UNO-DM-3.3/4.0/5.0/6.0-TL-PLUS-B (with display),<br>OR<br>ABB UNO-DM-5.0-TL-PLUS-B-QU,<br>ABB UNO-DM-6.0-TL-PLUS-B-Q<br>(no display) | Order code: 005316<br>(Optional) | ✓                           | ✓       |
| ABB PVI-3.0/3.6/4.2-TL-OUTD<br>(See Appendix II)  | x                                | ✓                           | ✓       |
| ABB PVI-5000/6000-TL-OUTD<br>(See Appendix II)  | x                                | ✓                           | ✓       |

See Appendix II for ABB PVI Managed AC Coupling installation instructions.

### No SP PRO installed? Important information

There is no special setup required if **ABB UNO** is **not connected** to an **SP PRO**.

**This document applies for SP PRO Series 2i. SP PRO Series I is not supported.**

# SP PRO ABB UNO Managed AC Coupling Installation Notes



## Important information

- ABB UNO can only be configured while minimum 200Vdc is applied to the solar inputs.
- The ABB UNO-DM-3.3/4.0/5.0/6.0-TL-PLUS-B inverters can be installed with any existing ABB Selectronic Certified inverter.
- For Wireless RS485 communication, please order Wireless RS485 link kit (Order Code: 005316) for: ABB UNO-DM-3.3/4.0/5.0/6.0-TL-PLUS-B (see Appendix I)
- To extend the range of the wireless devices, please order the Patch Antenna (Order code 004810)

# SP PRO ABB UNO Managed AC Coupling Installation Notes



## Installation check list

The follow table summarises the steps taken to set up an ABB UNO-DM in a Managed AC Coupled system. Once the system has been installed, use the following table to check off that each step has been completed.

Refer to the pages following the tables for detailed information on each of the installation steps.

| Installation step |   | Pages |
|-------------------|---|-------|
| 1                 | Install SP PROs as per manual   |       |
| 2                 | Install and configure batteries   |       |
| 3                 | ABB UNO must be Selectronic Certified   | 4 & 6 |
| 4                 | SP PRO firmware requirement – 12.20 or higher   | 6     |
| 5                 | ABB UNO AC Wiring   | 7     |
| 6                 | Communications Link (RS485)   | 9     |
| 7                 | Configure Additional Settings in SP PRO<br>Note: The SP PRO must be configured via SP LINK "Site Configuration Wizard" before configuring ABB UNO | 12    |
| 8                 | Configure the ABB UNO Q or QU – No front screen on ABB  | 13    |
| 9                 | Configure the ABB UNO – Front screen  | 15    |
| 10                | Test system function  | 18    |

# SP PRO ABB UNO Managed AC Coupling Installation Notes



## The Overview

The diagram below shows a managed AC coupled system with five ABB UNOs.

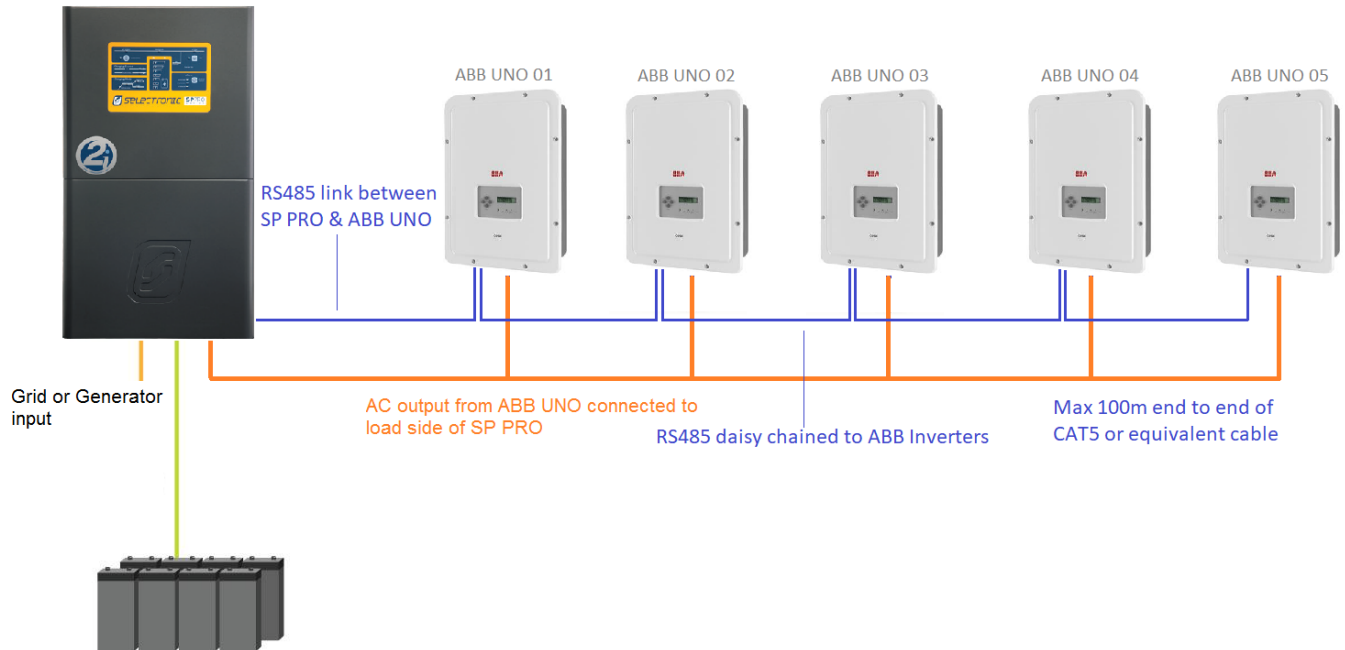

## System Requirements

To successfully install an SP PRO ABB managed system, there are particular requirements that need to be met.

- SP LINK Site Configuration Wizard must be used to verify:
  1. Combined maximum Fronius AC output
  2. Battery bank size
- SP PRO must have firmware version 10.01 or higher.
- All ABB UNOs must be Selectronic Certified.
- Maximum of five ABB UNOs per SP PRO.
- SP PRO Series 2i

# SP PRO ABB UNO Managed AC Coupling Installation Notes



## MINIMUM battery capacity for Solar Hybrid & Off Grid Systems

Each application will have a minimum battery capacity and a maximum allowable PV, please refer to the battery manufacturer's data sheet as well as the guidance given in the SP LINK Site Configuration Wizard.

### **Note:**

- a. *For a Solar Hybrid (grid connected) system, the minimum battery capacity that must be connected to the SP PRO varies depending on SP PRO model. When the system is islanded (e.g. during a grid outage) the SP PRO will limit the output of the AC coupled solar based on the actual installed battery size.*
- b. *For an Off-Grid system, the minimum battery capacity that must be connected to the SP PRO varies depending on SP PRO model, an overriding minimum battery capacity and the combined maximum ABB UNO AC Output.*

# SP PRO ABB UNO Managed AC Coupling Installation Notes



## SP PRO Firmware Requirements

1. SP PRO Software Version 12.20 or higher is required. To check software revision run SP LINK, connect to the SP PRO and go to Data View – Inverter Details– “SP PRO Revision” and “Software Version”
  2. The SP PRO must be Series 2i
- Older revisions of firmware must be updated to firmware revision 12.20 or higher.
  - Do not change any configuration settings until firmware is updated.

| Now                        | Today                  | DC History | AC History |
|----------------------------|------------------------|------------|------------|
| Inverter                   |                        |            |            |
| SP PRO Model               | SPMC482-AU             | Contr      | 1397       |
| SP PRO Ratings             | 48V DC, 7.5kW, 240V AC | Contr      | 23         |
| SP PRO Serial Number       | 141419                 | Contr      |            |
| SP PRO Revision            | 21                     | Power      | 1387       |
| SP PRO Mod Status          |                        | Power      | 4          |
| Software Version           | 12.20.M4               | Power      |            |
| String Inverters Supported | ABB Solar, Fronius     | Power      | 1387       |
| Grid Connect SW Version    | 2.00                   | Power      | 4          |
| SP PRO Total Run Time      | 19207.2 h              | Power      |            |

Data View – Inverter Details screen

## ABB UNO Must be Selectronic Certified

The ABB UNO must be Selectronic Certified. Other ABB UNOs will not operate correctly with the SP PRO in a managed AC coupled configuration.

**SELECTRONIC CERTIFIED**

# SP PRO ABB UNO Managed AC Coupling Installation Notes



## Installation

The SP PRO and ABB UNOs must be installed as per their respective installation instructions. Particular instructions directly related to Managed AC Coupling are listed below.

It is good practice to number each ABB UNO from 1 up to 5 so that each inverter can be easily referenced within SP LINK.

In a multiphase system, label each ABB UNO on L1, from L1-1 to L1-5. Do likewise for each of the ABB UNOs connected to L2, from L2-1 to L2-5 and so on.

## ABB UNO AC wiring

The ABB UNO AC output wiring must be connected to the AC Load terminals of the SP PRO in accordance with local wiring rules for correct operation.

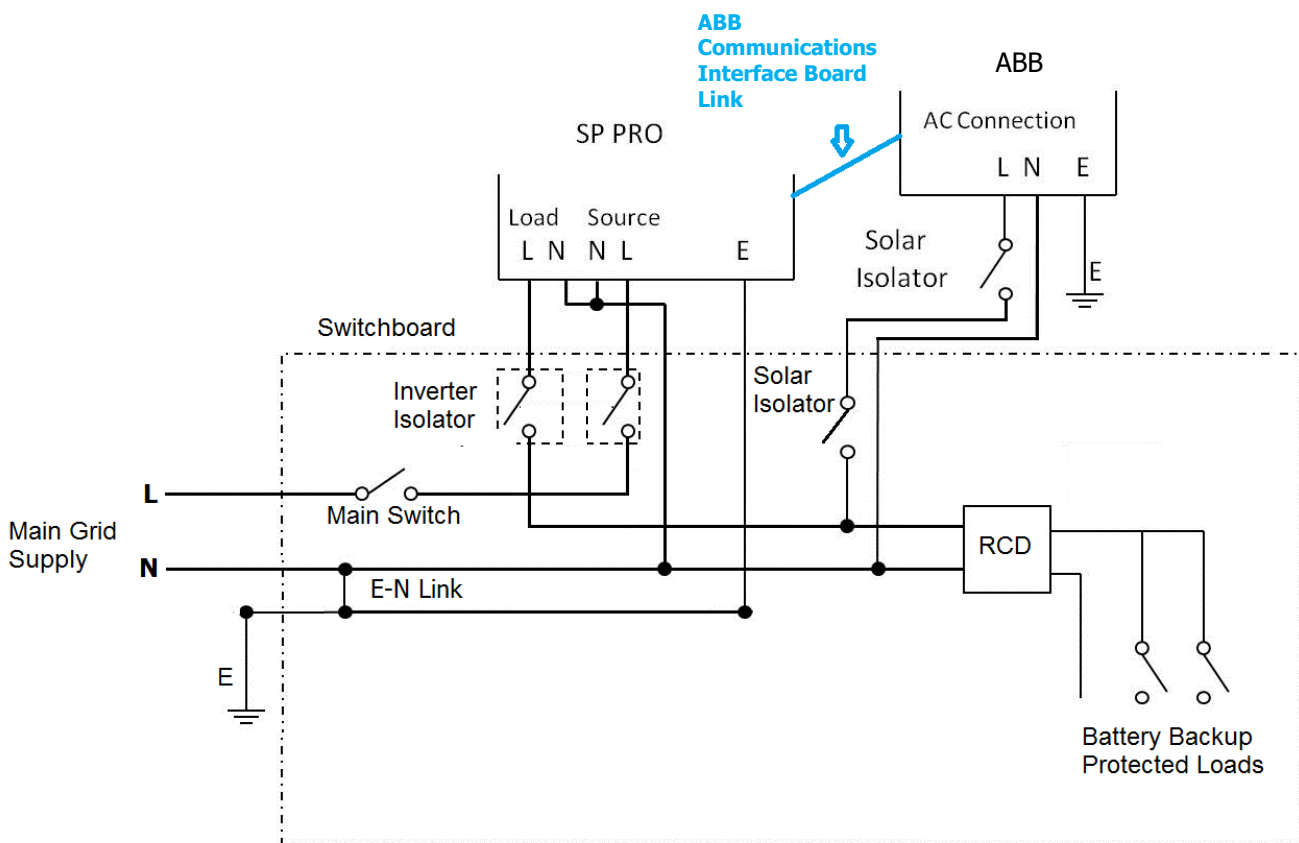

*ABB AC Wiring guide for Grid connected installation*

# SP PRO ABB UNO Managed AC Coupling Installation Notes

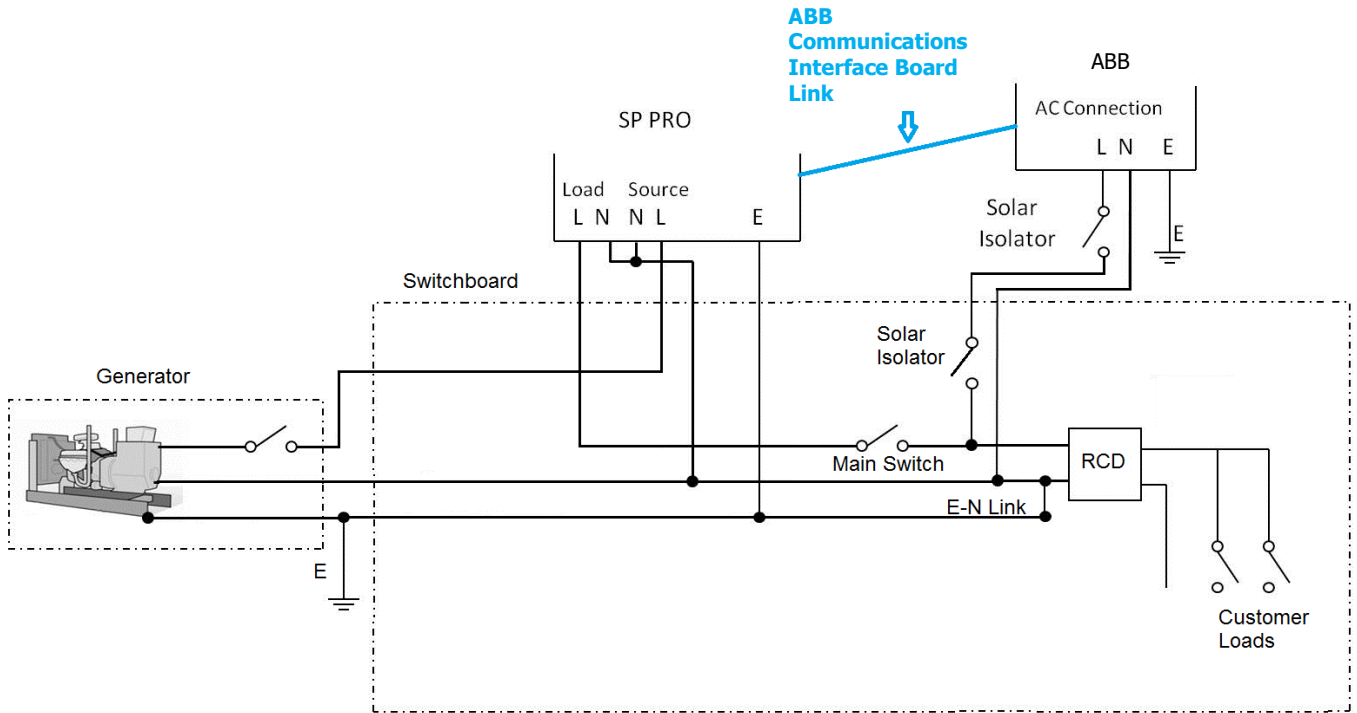

*ABB UNO AC Wiring guide for Off Grid installation*

**Note:** The system will not function correctly if the ABB UNOs are installed on the AC Source side of the SP PRO.



# SP PRO ABB UNO Managed AC Coupling Installation Notes



## Communications Link (RS485)

The communication link always starts at the SP PRO and links to each of the ABB UNOs in a daisy chain arrangement.

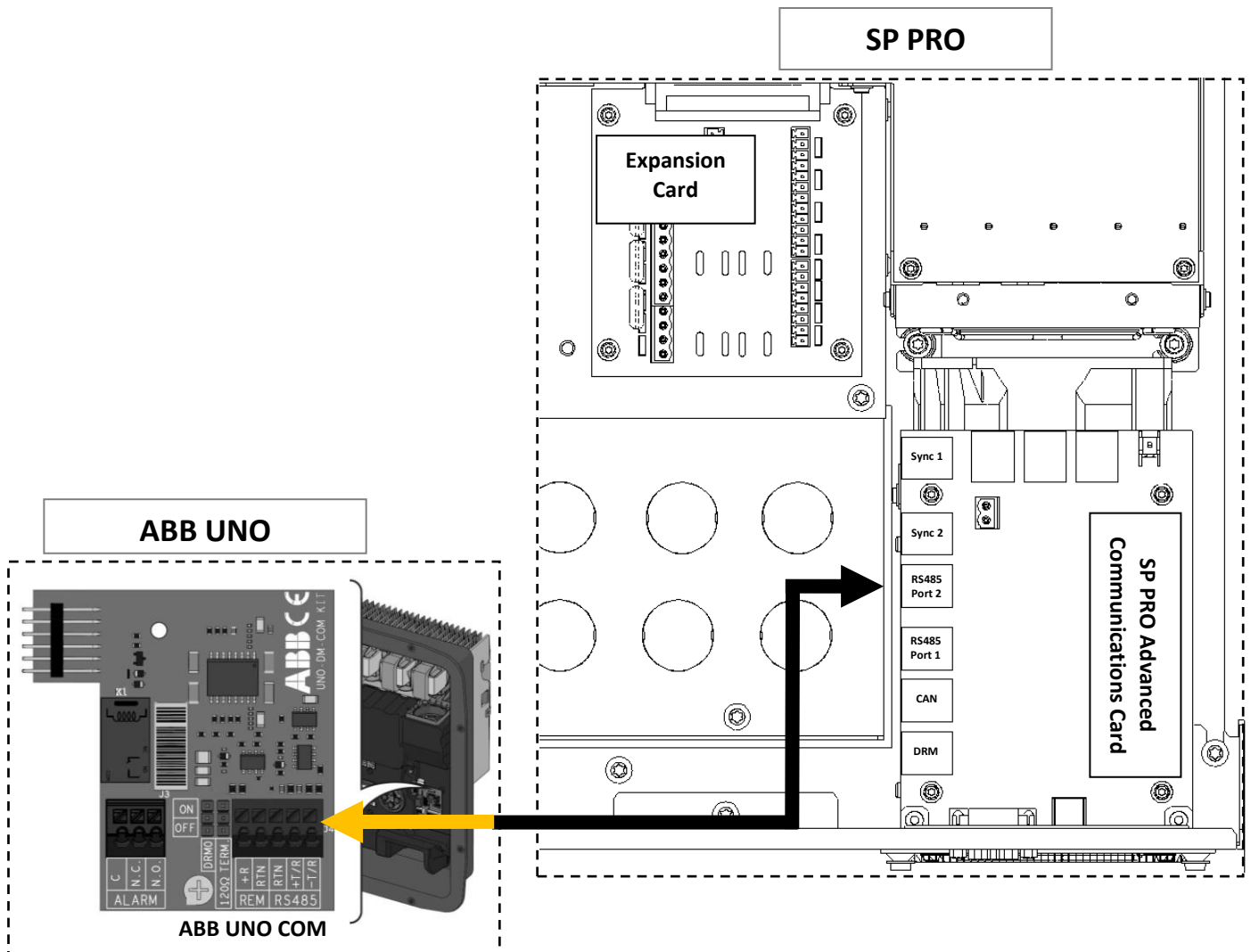

*SP PRO Connections (inside unit) – RS485 Port 2 RJ45 connector to RJ45 Adapter. RJ45 Adapter to ABB UNO RS485 connector.*

# SP PRO ABB UNO Managed AC Coupling Installation Notes



## RS485 Connection to First ABB UNO

Using the supplied CAT5 network cable, connect one end to the Advanced Communications Card "RS485-2" connection on the SP PRO. At ABB UNO 01 (Address# 02), connect the CAT5 cable to the RS485 adapter cable, and terminate the adapter into the ABB communications board.

**Note:** For wireless RS485 communication (Order code: 005316) please refer to Appendix I

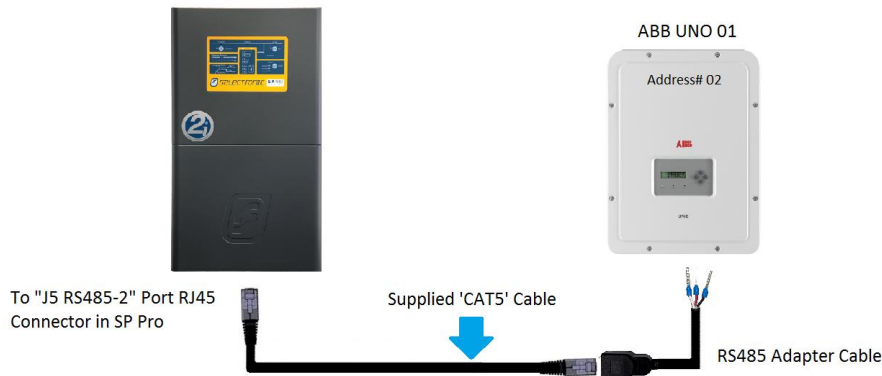

**Please Note:** To terminate the RS485 adapter cable into ABB communications board, push down the black tabs and insert the bootlace pinned wires into the board as follows.



*ABB UNO Connections (inside unit) – RS485 Adapter Wires terminated into the ABB communications board*

| Wire Colour | ABB Connector Label |
|-------------|---------------------|
| Red         | - T/R               |
| Black       | + T/R               |
| White       | RTN                 |

Set the 120Ω termination to "ON" if only a single unit is connected to the SP PRO. If more than one unit is connected, follow the instructions on the next page.

# SP PRO ABB UNO Managed AC Coupling Installation Notes



## Connecting ABB UNO link between Inverters 02 (Address# 03) to 05 (Address# 06)

The following configuration outlines the connection for multiple ABB UNOs to the first ABB UNO (ABB UNO 01). **If only a single ABB UNO is installed, skip to the next section (CONFIGURATION – ADDITIONAL SETTINGS)**

The ABB UNO RS485 is designed to interface with multiple ABB UNOs in a daisy chain arrangement as shown below.

When looping an ABB UNO to another ABB UNO, the termination jumper must be set to "OFF" (away from ON). For the last ABB UNO, the termination jumper must be set to "ON".

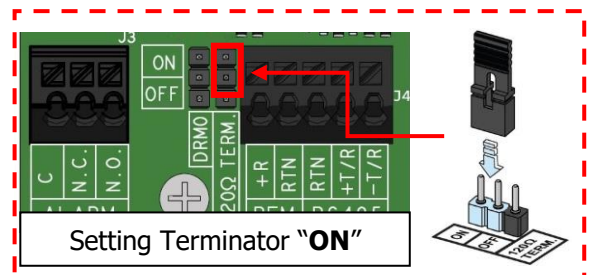
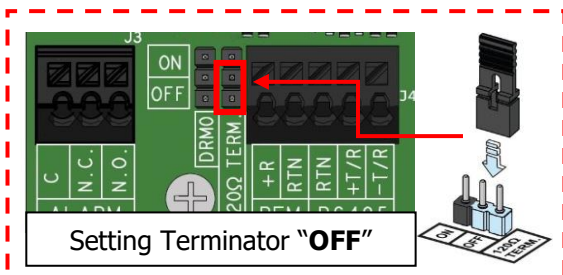
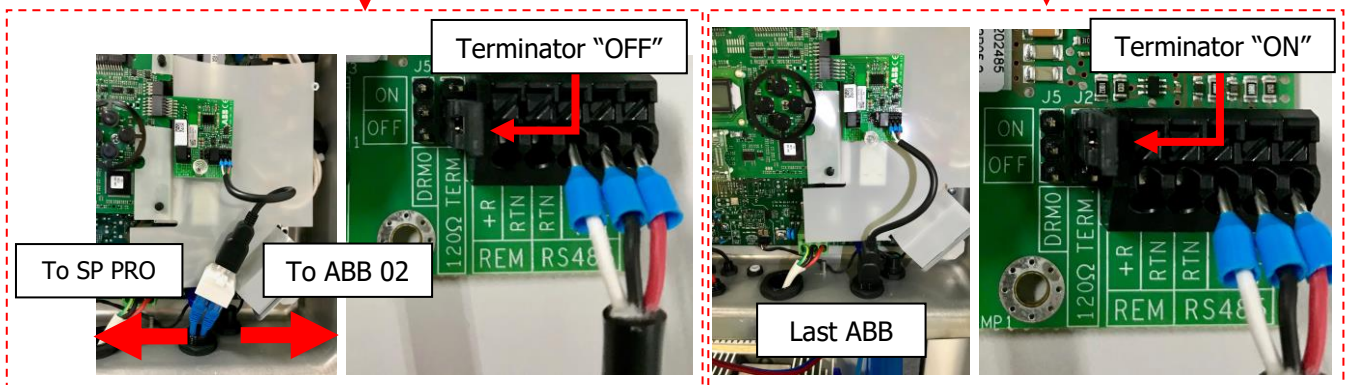
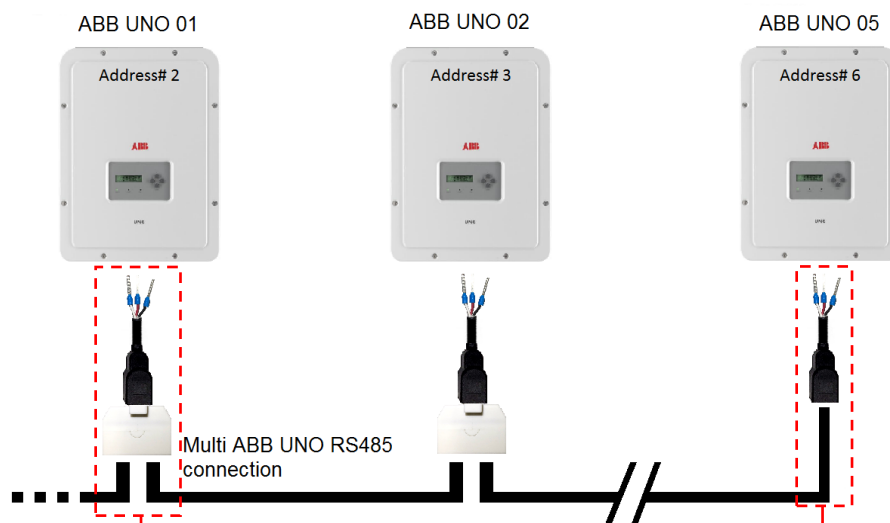

# SP PRO ABB UNO Managed AC Coupling Installation Notes



## Configuring Additional Settings in SP PRO

The Site Configuration wizard (in SP LINK 9.9 or higher) must be used to configure the SP PRO settings. Using the wizard will ensure all SP PRO settings are compatible with the managed AC coupled system.

The SP PRO must be configured before any of the ABB UNOs are energised.

The ABB UNOs RS485 must be set sequentially from Address# 02. (See "ABB UNO Configuration" section).

Make sure in the SP LINK tab **Configuration Settings > System**, the follow settings are set.

- Set **String Inverter** to **ABB Solar**.
- **Number of Devices** is set to the number of ABB UNOs installed in the system.

Managed AC Coupled Solar

**Islanding Power Limit\***  
[0.1 - 15.0 kW]  
3.6 kW

AC Source Limit Monitor  
**Monitoring Direction**  
Export

**Trip Power Limit**  
[0.0 - 250.0kW]  
50.00 kW

**Trip Time\***  
[0 - 1000 s]  
5

L1  
**String Inverter\***  
ABB Solar

**Number of Devices\***  
[1 - 5]  
2

**Fallback Power**  
Disabled

*SP LINK - Configuration Settings – System tab*

In the example used above, two ABB UNOs are connected to the SP PRO.

# SP PRO ABB UNO Managed AC Coupling Installation Notes



## ABB UNO Q Configuration (NO DISPLAY)

**NOTE:** If your ABB UNO has a display, go to ABB UNO Configuration (DISPLAY).

The settings listed below are required to be configured in each ABB UNO in order for the system to operate correctly.

Each ABB UNO must be set to an **RS485 node address from 2 to 6** as appropriate.

1. Isolate the AC and connect the DC supply to the ABB UNO(s) and ensure that the DC supply (Minimum 200 VDC) is present at the ABB UNO.
2. Connect the WiFi antenna to the bottom of the ABB UNO
3. Follow the instructions in the ABB quick installation guide to connect your mobile phone to the ABB UNO inverter and follow the instructions on the screen until you reach the dashboard screen.
4. Select the menu, communications option then RS485.

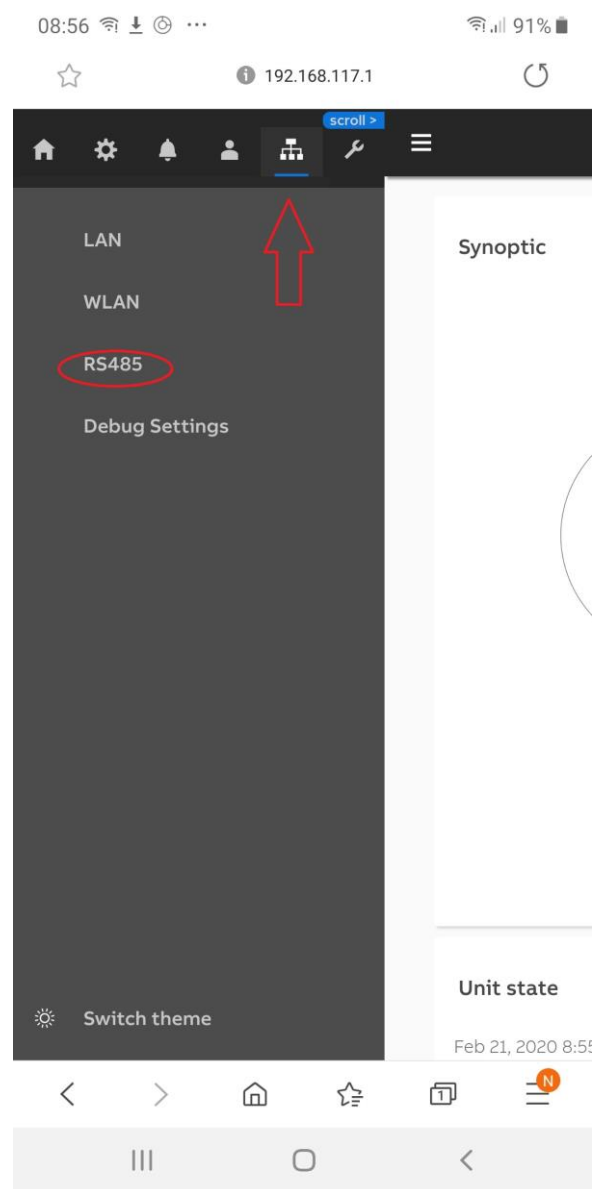
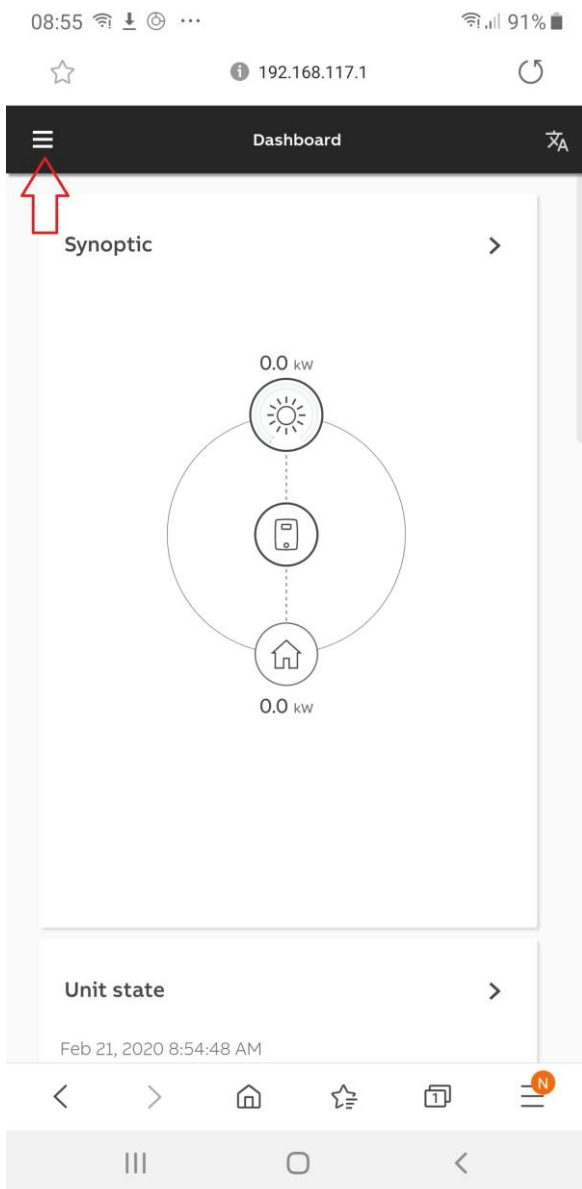

# SP PRO ABB UNO Managed AC Coupling Installation Notes



08:56 91%

192.168.117.1

### RS485

#### RS485 Main

RS485 Node Address

RS485 Baud Rate

RS485 Parity Mode

RS485 Protocol Type

Save

5. Once the RS485 Screen is displayed enter the details as shown above

- If only one ABB UNO is installed then the RS485 node address must be set to 2.
- If more than one ABB UNO is installed then the RS485 node address must be allocated sequentially starting from 2.
- Once details are entered then select the Save button to save the configuration.

**Note:** Do Not skip any address numbers in the sequence.

**Continue to section "System Commissioning – Additional Tests"**

# SP PRO ABB UNO Managed AC Coupling Installation Notes



## ABB UNO Configuration (DISPLAY)

The settings listed below are required to be configured in each ABB UNO in order for the system to operate correctly.

Each ABB UNO must be set to an **RS485 address from 2 to 6** as appropriate.

6. Isolate the AC and connect the DC supply to the ABB UNO(s) and ensure that the DC supply (Minimum 200 VDC) is present at the ABB UNO.
7. When the ABB UNO is powered for the first time, select the "Nation" of installation. For Australia and New Zealand select "AS 4777" and press the **ENTER** key once and to save the setting, hold the ENTER key for 5 seconds, the ABB UNO will reset.
8. Step through the initial stages of commissioning the inverters date and time, current input mode, Grid select, country select...etc, until the following is displayed on the screen.

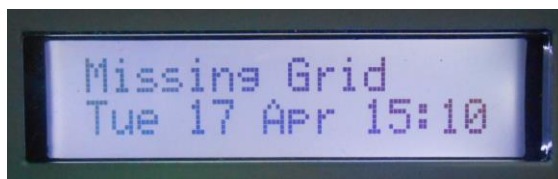

**Note:** When an ABB UNO is powered without the AC, "Missing Grid" will be displayed on screen.

9. Once the display is active on the ABB UNO, enter the main menu. To enter main menu, press the **ESC** button to once, then using the **DOWN** key, scroll to "**System**" and press **ENTER**. The **ESC** is also used to escape back to the previous menu or to edit previous digits.

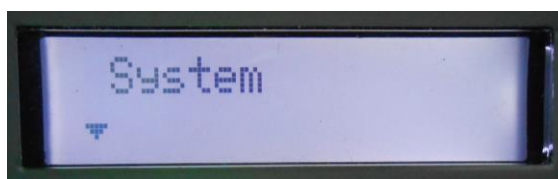

# SP PRO ABB UNO Managed AC Coupling Installation Notes



10. Scroll to **Settings** and press **ENTER**.

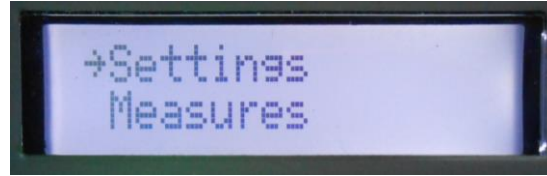

11. To access **Settings**, a passcode is required. By default, **0000** is the passcode or by pressing the **ENTER** key four times to access the setting option. Use **ENTER** key to confirm an action or to access submenus

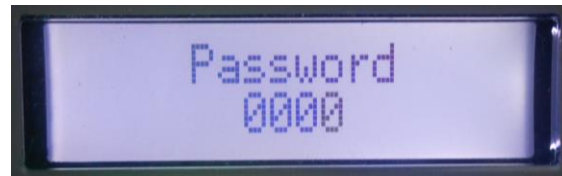

12. Scroll to **Set RS485 Com** and press **ENTER**.



13. Scroll to **Set Port** and press **ENTER**.



14. Scroll to **Address RS485** and press **ENTER**.





# SP PRO ABB UNO Managed AC Coupling Installation Notes



- a. If only one ABB UNO is installed then the address must be set to 2/63.
- b. If more than one ABB UNO is installed then the address must be allocated sequentially starting from 2/63 (i.e. first ABB UNO = 2/63, second ABB UNO = 3/63, third ABB UNO = 4/63 etc).
- c. Once the "Inverter Number" is selected, press the **ENTER** button to configure and return to the "Set Port" menu.

**Note:** Do Not skip any address numbers in the sequence

15. Scroll to **Protocol** and press **ENTER**.



- a. Scroll **DOWN** and select **Aurora (slave)** and press the **ENTER** button to configure and return to the "Set Port" menu.

16. Press the **ESC** button five times to return to the main display.

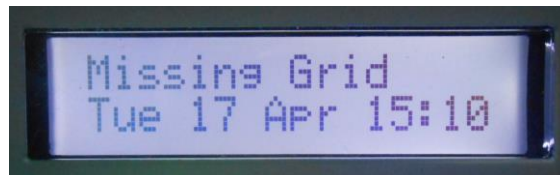

17. If there are multiple ABB UNOs installed, repeat for all others.

18. When all is configured, the ABB UNO display screen will cycle through the amount of energy currently fed automatically.

**Continue to section "System Commissioning – Additional Tests"**

# SP PRO ABB UNO Managed AC Coupling Installation Notes



## System Commissioning – Additional Tests

In addition to the normal system testing that would be performed, the following additional tests must be performed as detailed below.

**Note:** Make sure that only DC is connected at this stage.

## Communications Link Verification

The correct operation of the ABB Managed AC Coupling relies on the Communications Link. It is vital that the communications link (RS485) connection has been setup correctly before operating the AC coupled system.

1. Check that all the RS485 connections have been connected correctly.
2. Isolate the AC and connect the DC supply to the ABB UNO. Make sure that the DC supply is present at the ABB UNO and its display is on.
3. Using SP LINK, connect to the SP PRO. In the Data View > Now tab there should be a model number displayed for each of the installed inverters.

|                       |                |
|-----------------------|----------------|
| AC Solar #1           | UNO-DM-3.3-TL  |
| RS485 Device Address: | 2              |
| AC Energy Today       | Not Applicable |
| AC Power              | 0.73 kW        |
| AC Volts              | 244.1 V        |
| AC Current            | Not Applicable |
| DC Power              | Not Applicable |
| DC Volts              | 276.7 V        |
| DC Current            | Not Applicable |
| Temperature           | 27 °C          |
| AC Power Peak Today   | 0.73 kW        |

The communication link may be further tested using the AC Solar Link Test found in SP LINK under the Service Settings tab.

1. In the Service Settings tab click the "Reset Counters" button.
2. Wait 2 minutes and check that the error count remains at zero for all the connected ABB UNOs. (An error count of 5 or less per minute is acceptable, but in this case, it is good practice to check the wiring and that the termination resistors are set correctly in the SP PRO and ABB UNO.

Once the Communications link has been verified for each ABB UNO, the AC feeds to each ABB UNO can be switched on and full system testing and verification can be performed.

## Testing the Failsafe on the RS485 Link

Once the system is operational, unplug the RS485 communications link from the SP PRO to the ABB UNOs. Wait 1 minute and check that the output of each of the ABB UNOs has dropped to approximately 0.1kW.

AC Solar Link Test  
Errors or non-responses from grid-tie inverters can indicate quality of link.

Counting while grid tie inverter is off is normal.

|         |   |
|---------|---|
| Link #1 | 0 |
| Link #2 | 0 |
| Link #3 |   |
| Link #4 |   |
| Link #5 |   |

Reset Counters

# SP PRO ABB UNO Managed AC Coupling Installation Notes



## Appendix I: Wireless RS485 for ABB UNO-DM Link

### Introduction

This instruction will show how to install the Wireless RS485 link Kit (Order code 005316).

This details the additional steps needed to install a Wireless RS485 link into a SP PRO ABB UNO-DM Managed AC Coupled system.

### Important information

1. This document needs to be read in conjunction with:
  - SP PRO AU Instruction Manual
  - Relevant ABB UNO-DM Installation Manual
2. SD1100 RS485 Wireless adaptors are powered from the supplied plug packs. The plug packs must be connected to the same AC power circuit as the connected ABB UNOs. This is normally the AC load side of the SP PRO.
3. To extend the range of the wireless devices, please order the Patch Antenna (Order code 004810).

### Additional information

Selectronic web site – <http://www.selectronic.com.au> or contact the Selectronic team.

### Legend to diagrams in this document



SP PRO 2i



Selectronic Certified  
ABB UNO-DM Grid  
inverter



SD1100 RS485  
Wireless adaptor  
with dipole  
antenna



SD1100 RS485  
Wireless adaptor  
with patch  
antenna

# SP PRO ABB UNO Managed AC Coupling Installation Notes



## Overview

The diagrams below illustrate the options for single phase managed AC coupled system with ABB UNO-DM inverters.

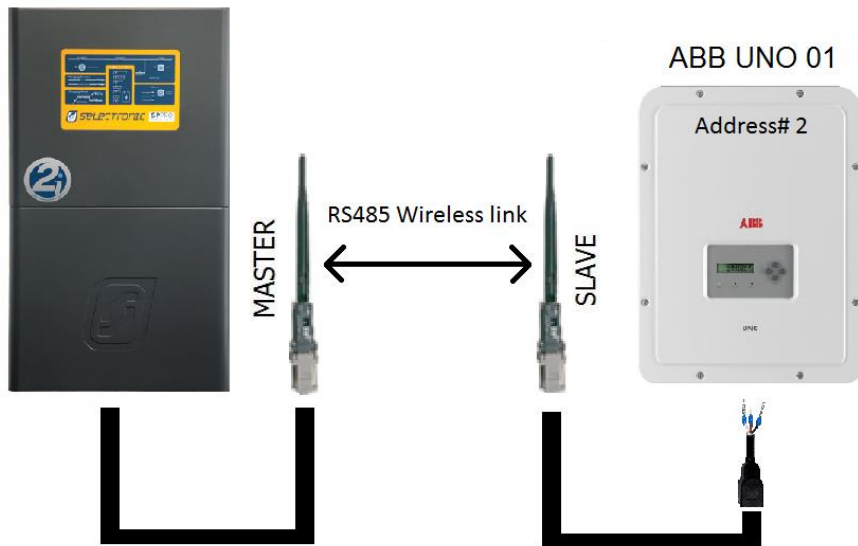

Figure 1: Single phase system with one wireless ABB UNO-DM

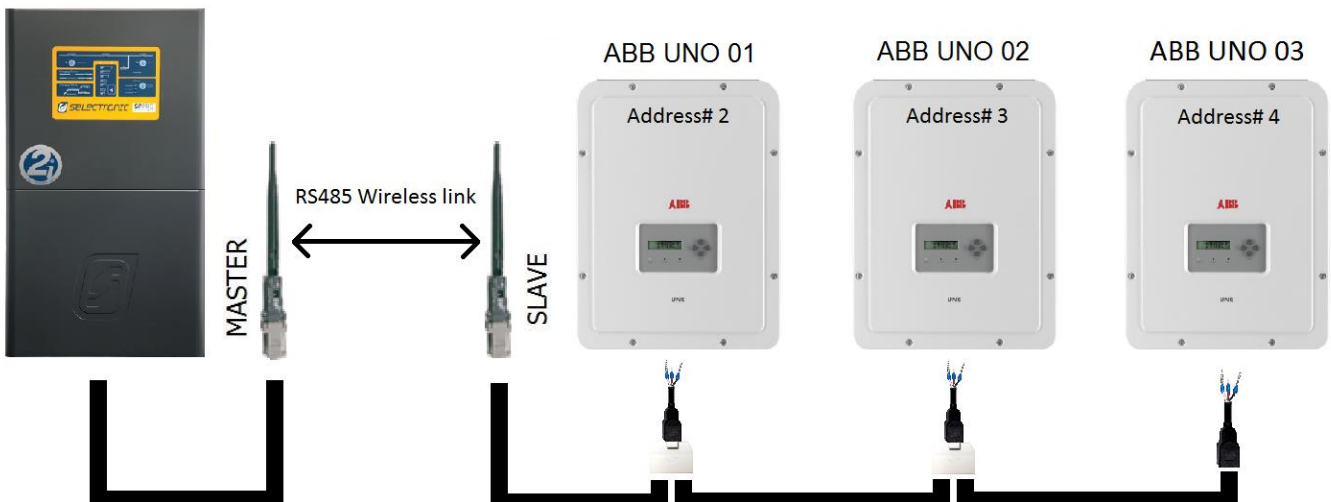

Figure 2: Single phase system with multiple wireless ABB UNO-DM

# SP PRO ABB UNO Managed AC Coupling Installation Notes



## Installing a separate pair of wireless RS485 devices on each phase

The diagram below shows a three-phase managed AC coupled system with three ABB UNOs per phase. A separate pair of Wireless RS485 link Kit (Order code 005316) must be used for each phase.

**Note:** When using multiple Wireless RS485 device pairs use Patch Antennas on each of the devices at the local end of the system (SP PRO end). This will reduce the interference between devices. Keep patch antennas separated by a minimum of 300mm.

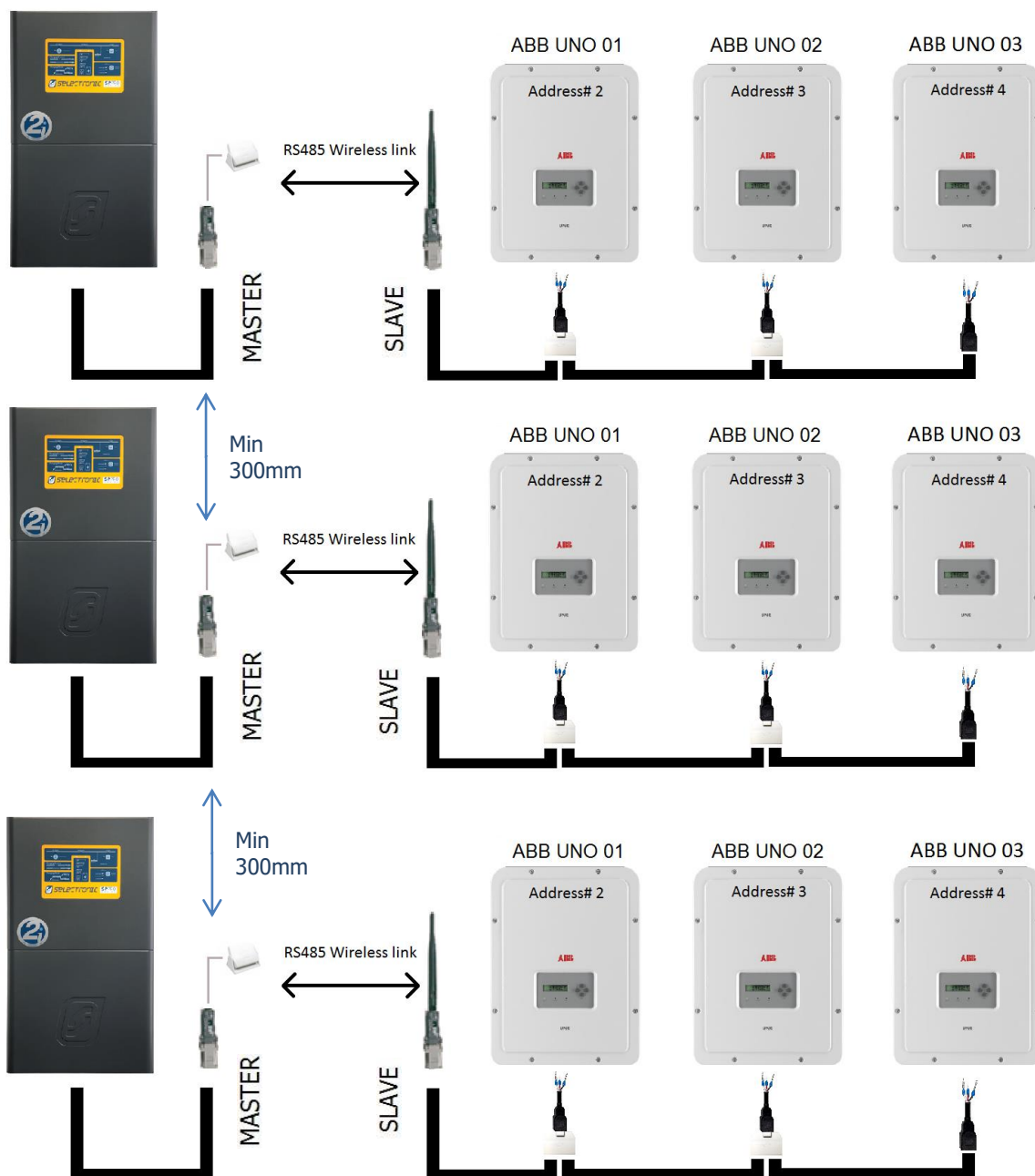

Figure 3: Overview of three phase system using Wireless RS485

# SP PRO ABB UNO Managed AC Coupling Installation Notes



## Wireless link restrictions

The wireless link uses the same frequency band as Wi-Fi and Bluetooth (2.4GHz). Any obstructions between the two devices or interference from other devices using the same frequency band (other blue tooth or Wi-Fi devices) will have a significant impact on their range.

To achieve the maximum range of 200m there must be line of sight between the two devices and no interference. As a rule of thumb, each obstruction that is equivalent to a stud wall will reduce the distance by about 20%. Mud brick walls, double brick or concrete walls will have a much larger impact on the range.

Any obstruction from the landscape such as levy banks, hills or undulation land will totally block the signal and the wireless link will not work.

If more than one wireless link is required within the same installation (such as a three-phase system or multiple remote sites) then the interference between the devices will further reduce the distance. In this case it is recommended that a patch antenna be used on all local Wireless devices.

## Extending the Wireless Range

If the required distance is longer than the specified 200m clear line of site, or there are multiple devices being used then the range of the devices can be extended by replacing the dipole antenna with a "patch" antenna. The table 1 below gives an indication of the expected range when using a combination of dipole and patch antennas:

Table 1: Maximum "Line of site" distance between Wireless RS485 device pairs.

| Local Wireless device antenna        | Remote wireless device antenna       | Max distance, one pair of devices (line of sight) | Max. distance, multiple pair of devices (line of sight) |
|--------------------------------------|--------------------------------------|---|---|
| Dipole (supplied)                    | Dipole (supplied)                    | 200m  | Not recommended   |
| Patch – Optional (stock code 004810) | Dipole (supplied)                    | 300m  | 150m  |
| Patch – Optional (stock code 004810) | Patch – Optional (stock code 004810) | 500m  | 250m  |



Optional Patch Antenna to extend the range of the wireless devices (Selectronic Order Code 004810)

**Note:** Patch Antenna is directional and must be mounted in a fixed position that is directly facing the antenna of the other wireless device.

# SP PRO ABB UNO Managed AC Coupling Installation Notes



## Installation

**Note:** If you have been supplied with an "AC Coupled Interface PCA" and have an old communications card, please refer to Appendix III for instructions on how to configure RS485 communications.

The communication link starts at the SP PRO and links to the **MASTER SD1100 RS485 Wireless adaptor**.

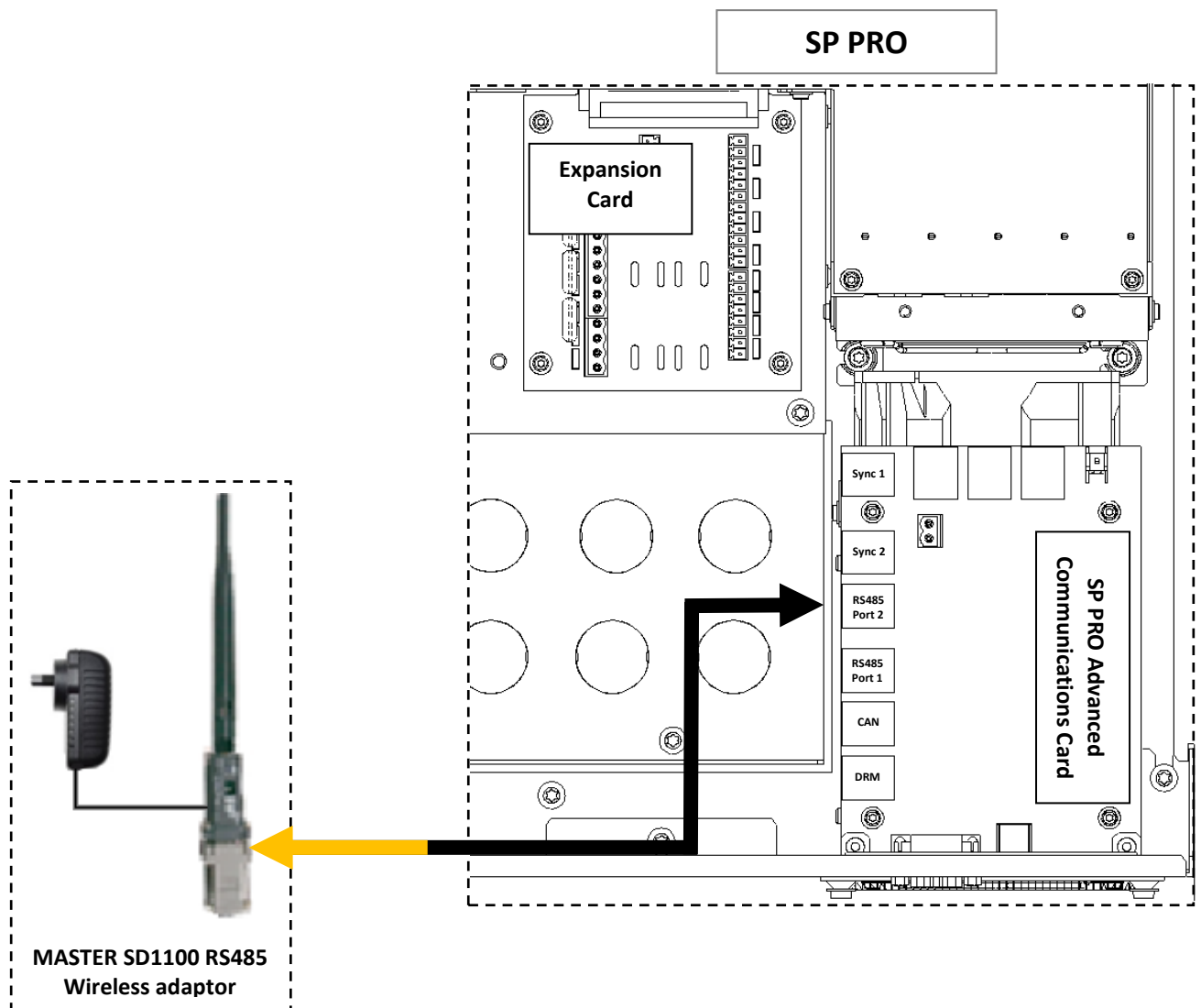

*SP PRO Connections (inside unit) – RS485 Port 2 RJ45 connector to RJ45 Adapter to ABB UNO RS485B connector*

# SP PRO ABB UNO Managed AC Coupling Installation Notes



## Wireless connection to ABB UNO-DM

Using the supplied 'CAT5' network cable connect one end to the SLAVE SD1100 RS485 Wireless adaptor. At ABB UNO 01 (Address# 02), connect the CAT5 cable to the RS485 adapter cable, and terminate the adapter into the ABB communications board.

**Note:** SD1100 RS485 Wireless adaptors are powered from the supplied plug packs. The plug packs must be connected to the same AC power circuit as the connected ABB UNOs. This is normally the AC load side of the SP PRO.

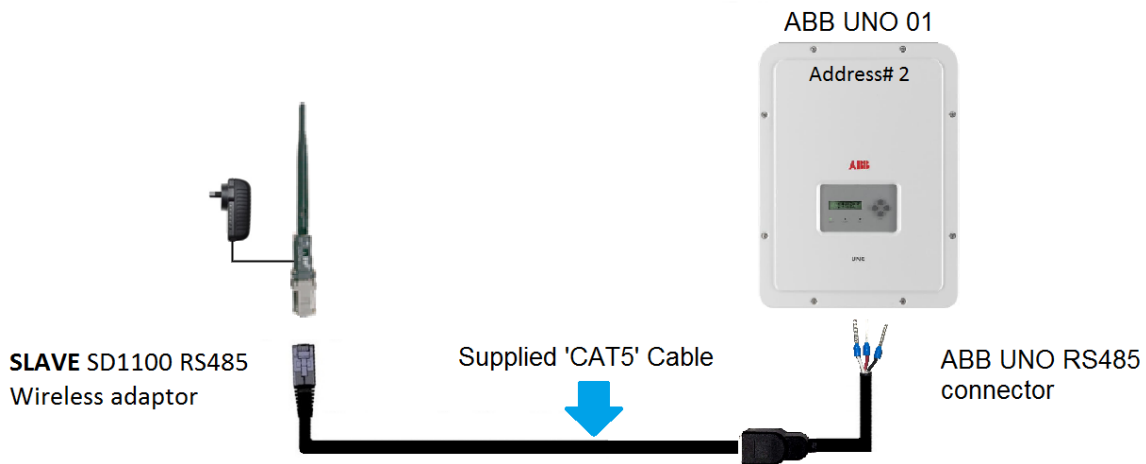

**Please Note:** To terminate the RS485 adapter cable into ABB communications board, push down the black tabs and insert the bootlace pinned wires into the board as follows.



*ABB UNO Connections (inside unit) – RS485 Adapter Wires terminated into the ABB communications board*

| Wire Colour | ABB Connector Label |
|-------------|---------------------|
| Red         | - T/R               |
| Black       | + T/R               |
| White       | RTN                 |



# SP PRO ABB UNO Managed AC Coupling Installation Notes



The last ABB UNO of the daisy chain must be terminated provided jumper at the pins marked "120Ω TERM." must be placed in the ON position as shown.

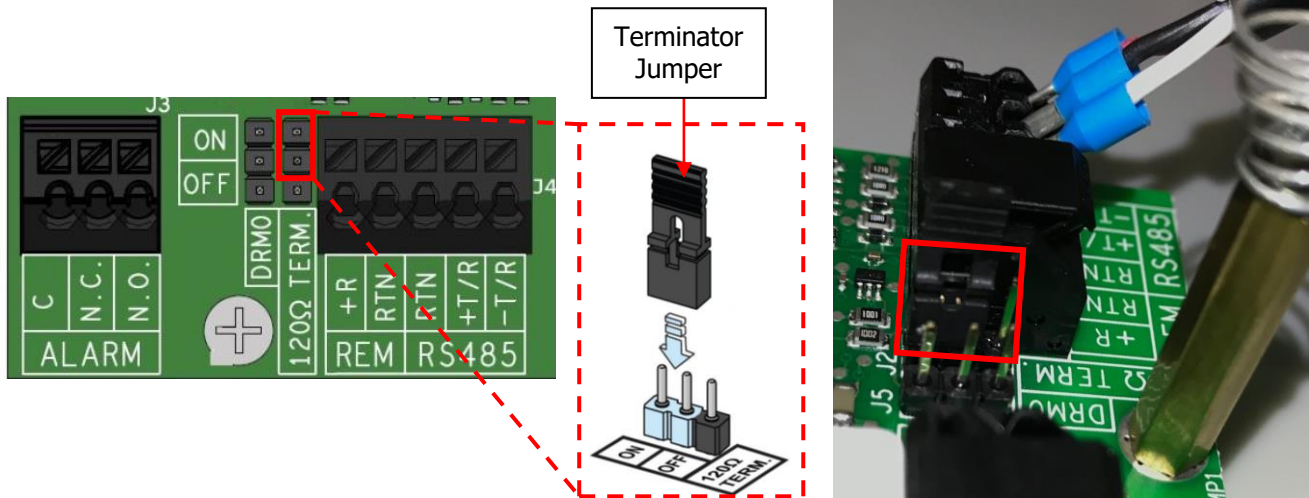

**Note:** When connecting multiple ABB UNOs together, the terminating jumper must be set to OFF "120Ω TERM." for all ABB UNO except the last inverter of the daisy chain (ON).

## Power for the Wireless RS485 devices

The RS485 devices are powered from the supplied plug packs. The plug packs must be connected to the same AC power circuit as the connected ABB UNOs. This is normally the AC load side of the SP PRO.

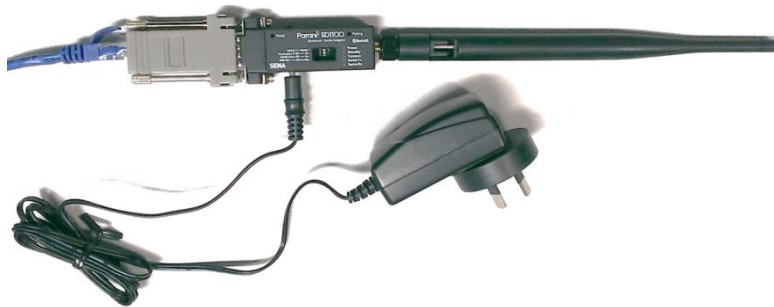

Figure 5: SD1100 RS485 Wireless adaptor power connection



## Appendix II: SP PRO ABB PVI Managed AC Coupling

### Introduction

This section details the additional steps needed to install the managed AC Coupling system for ABB PVI-3.0/3.6/4.2-TL-OUTD and ABB PVI-5000/6000-TL-OUTD string inverters to the SP PRO.

**Note:** Installation note applies for SP PRO Series II Rev21 and above

| Applicable ABB UNO models   | Suitable System Application |         |
|-----------------------------|-----------------------------|---------|
|                             | Off Grid                    | On Grid |
| ABB PVI-3.0/3.6/4.2-TL-OUTD | ✓                           | ✓       |
| ABB PVI-5000/6000-TL-OUTD   | ✓                           | ✓       |

### Important information

ABB can only be configured while minimum 200Vdc is applied to the solar inputs.

# SP PRO ABB UNO Managed AC Coupling Installation Notes



## The Overview

The diagram below shows a managed AC coupled system with five ABB PVI inverters.

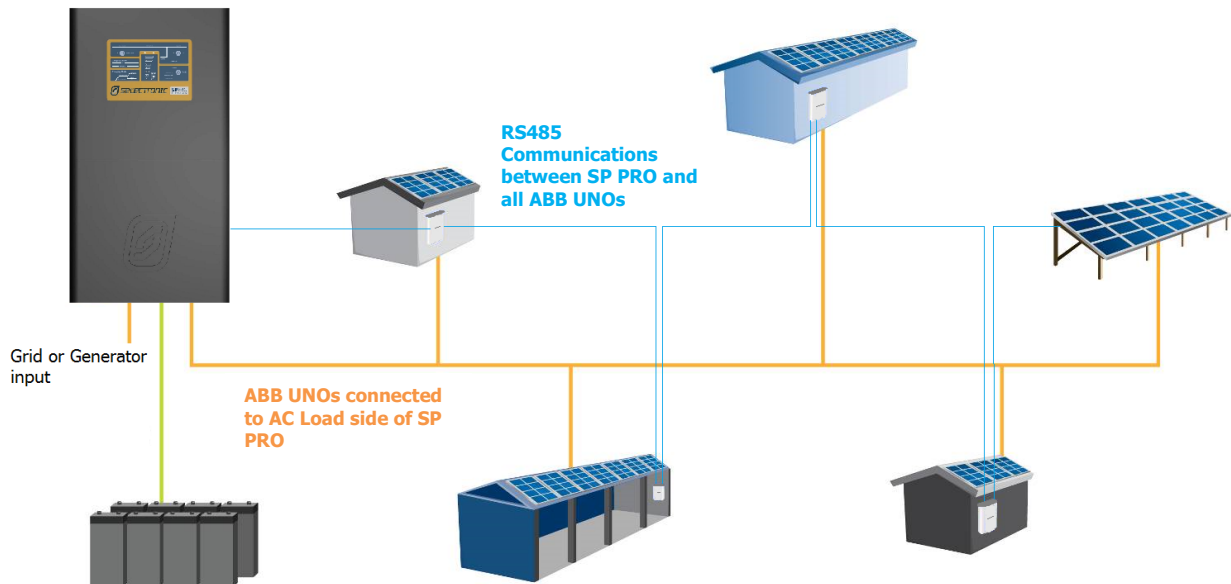

## System Requirements

To successfully install an SP PRO ABB PVI managed system, there are particular requirements that need to be met.

- This installation document is applicable to **SP PRO series II (revision 21 or greater)** inverters only with 8.0 Firmware or greater.
- Combined maximum AC output of all the connected ABB UNOs must not exceed twice the continuous rating of the SP PRO (Except for SPLC1202 which is 35kW).
- Battery bank must be sized to suit the SP PRO model and the combined maximum AC Output power of the ABB UNOs.
- SP PRO must have firmware version 8.0 or greater.
- All ABB UNOs must be Selectronic Certified (Selectronic signage on front access cover).
- Maximum of 5 ABB UNOs per SP PRO

# SP PRO ABB UNO Managed AC Coupling Installation Notes



## SP PRO Requirements

- The SP PRO units' revision must be 21 or later (series II).
- SP PRO Software Version 8.0 or later is required. To check software revision run SP LINK, connect to the SP PRO and go to Data View – Inverter Details – “SP PRO Revision” and “Software Version”

| Now                        | Today                  | DC History | AC History  |
|----------------------------|------------------------|------------|-------------|
| Inverter                   |                        |            |             |
| SP PRO Model               | SPMC482-AU             |            | Contrn 1397 |
| SP PRO Ratings             | 48V DC, 7.5kW, 240V AC |            | Contrn 23   |
| SP PRO Serial Number       | 141419                 |            | Contrn      |
| SP PRO Revision            | 21                     |            | Power 1387  |
| SP PRO Mod Status          |                        |            | Power 4     |
| Software Version           | 12.20.M4               |            | Power       |
| String Inverters Supported | ABB Solar, Fronius     |            | Power 1387  |
| Grid Connect SW Version    | 2.00                   |            | Power 4     |
| SP PRO Total Run Time      | 19207.2h               |            | Power       |



\*00114713\*



ACN 063 863 785

Serial No: **114713**  
GQNJSBX

Revision: **21**

1 2 3 4 5 6 7 8

Packed weight: **45 kg**

SGSE/090398

CB:FI-11386

Model No:

**SPMC241**

Stock Code: 004724

*Packaging Label indicating Revision: 21*

*Data View – Inverter Details screen*

- Older revisions of firmware must be updated to firmware revision 8.0 or later.
- Do **NOT** change any configuration settings until firmware is updated.

**Note:** Selectronic web site – <http://www.selectronic.com.au> for latest SP PRO firmware and Tech Note 34 SP PRO Firmware Update Procedure.

ABB Must be Selectronic Certified

The ABB UNO must be Selectronic Certified. Other ABB UNOs will not operate correctly with the SP PRO in a managed AC coupled configuration.



# SP PRO ABB UNO Managed AC Coupling Installation Notes



## Installation

The SP PRO and ABB UNOs should be installed as per their respective installation instructions. Particular instructions directly related to Managed AC Coupling are listed below.

It is good practice to number each ABB UNO from 1 up to 5 so that each inverter can be easily referenced within SP LINK. In a three phase AC coupled system label each ABB UNO L1-1 to L1-5 for the ABB UNOs connected to SP PRO L1, L2-1 to L2-5 for those connected to L2 and so on.

**Note:** The address numbers programmed into ABB solar inverters start from 2 and go up to 6 (instead of 1 to 5). When viewing Data in SP Link, inverter #1 is connected to ABB UNO address 2, inverter #2 is connected to ABB UNO address 3 etc.

## ABB AC wiring

The ABB AC output wiring must be connected to the AC Load terminals of the SP PRO in accordance with local wiring rules for correct operation.

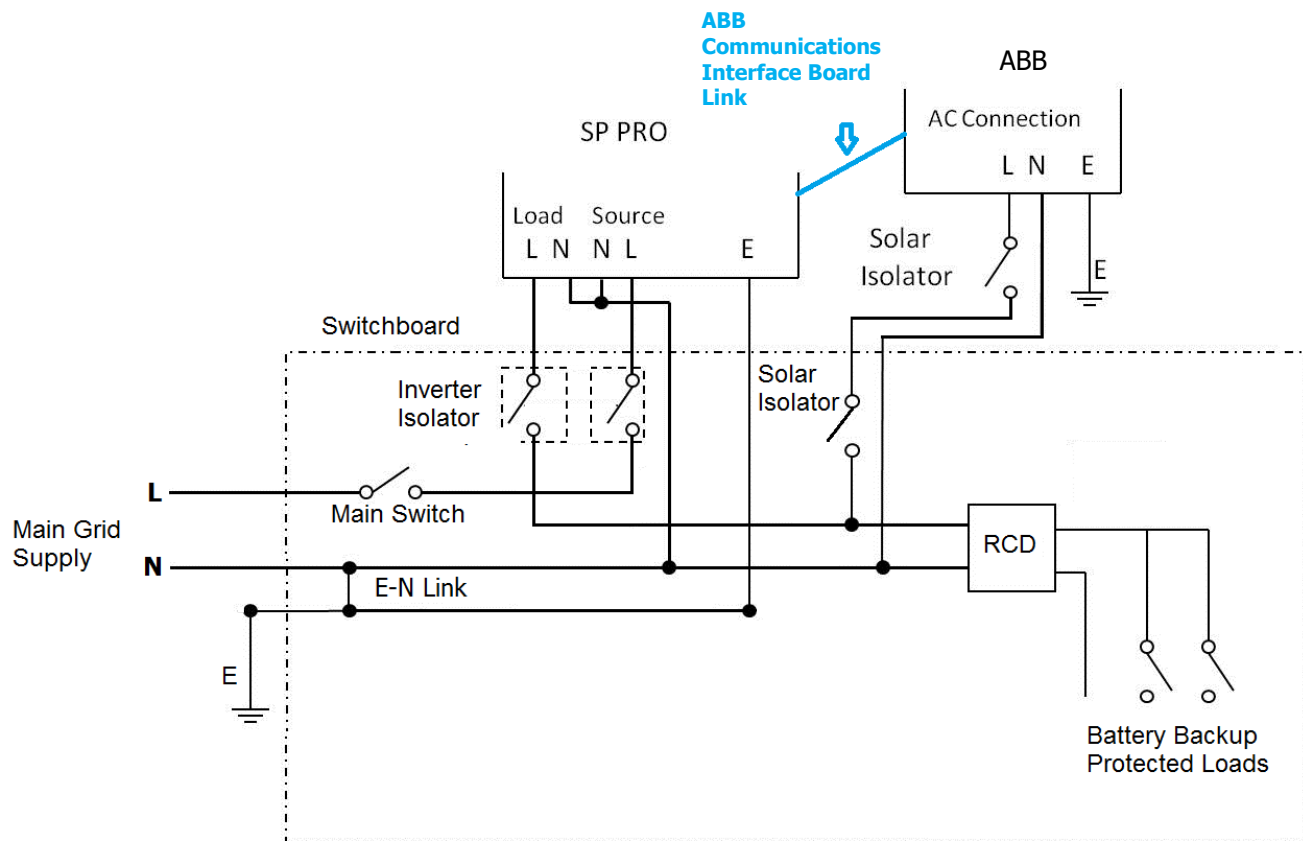

*ABB AC Wiring guide for Grid connected installation*

# SP PRO ABB UNO Managed AC Coupling Installation Notes

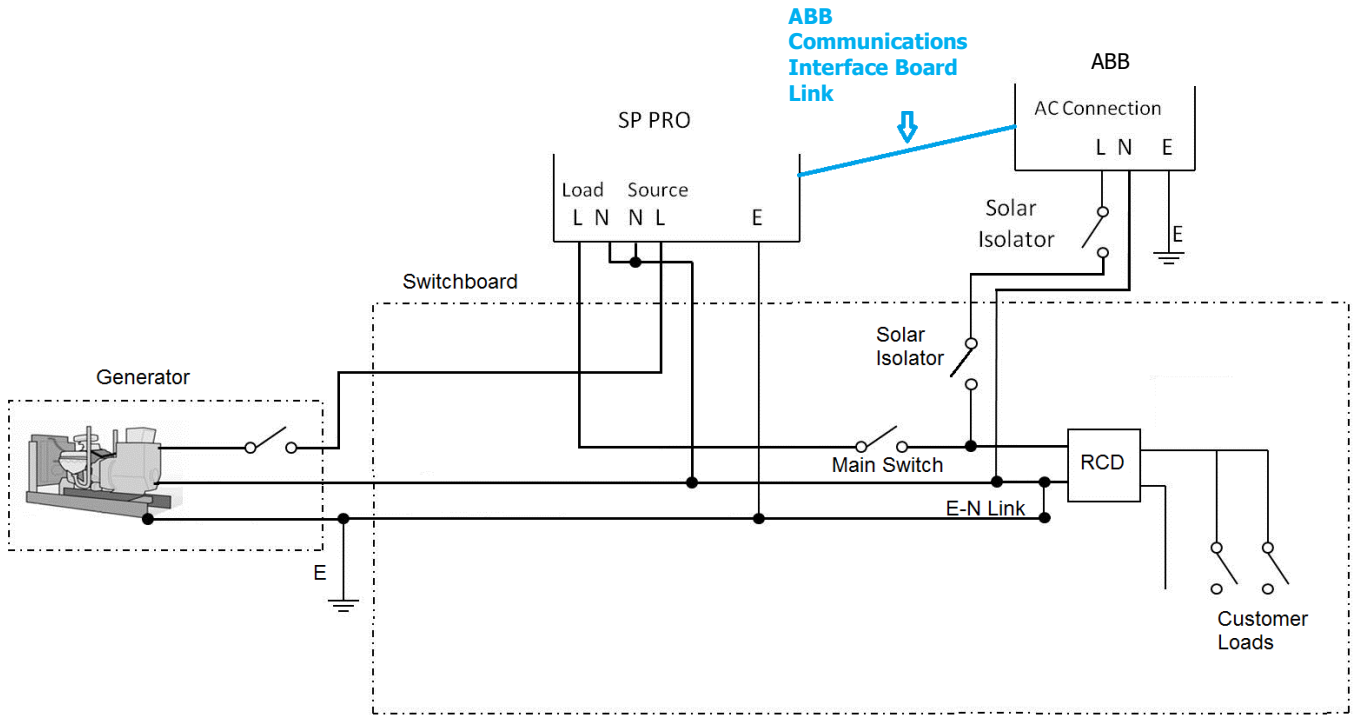

*ABB AC Wiring guide for Off Grid installation*

**Note:** The system will NOT function correctly if the ABB UNOs are installed on the AC Source side of the SP PRO.

# SP PRO ABB UNO Managed AC Coupling Installation Notes



## Communications Link (RS485)

The communication link always starts at the SP PRO and links to the "AC Coupled Interface PCA", then connects to all the ABB UNOs in a daisy chain arrangement and finishes at the last ABB UNO. The ABB UNO link is used to connect subsequent ABB UNOs ON the same phase as the SP PRO. Do Not Connect ABB UNOs on different phases together.

To install the AC Coupled Interface PCA, remove the bottom two screws from the Expansion Card and replace them with the provided 2x stand offs. Then mount the AC Coupled Interface PCA to the Expansion Card inside the SP PRO close to the Serial Communication PCA as illustrated.

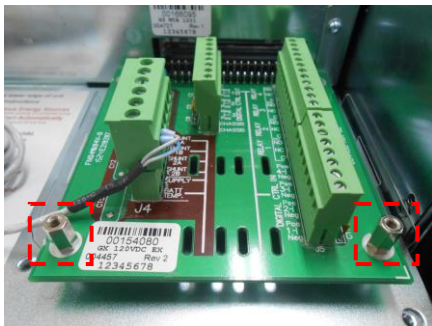

Expansion Card bottom screws replaced with stand offs.

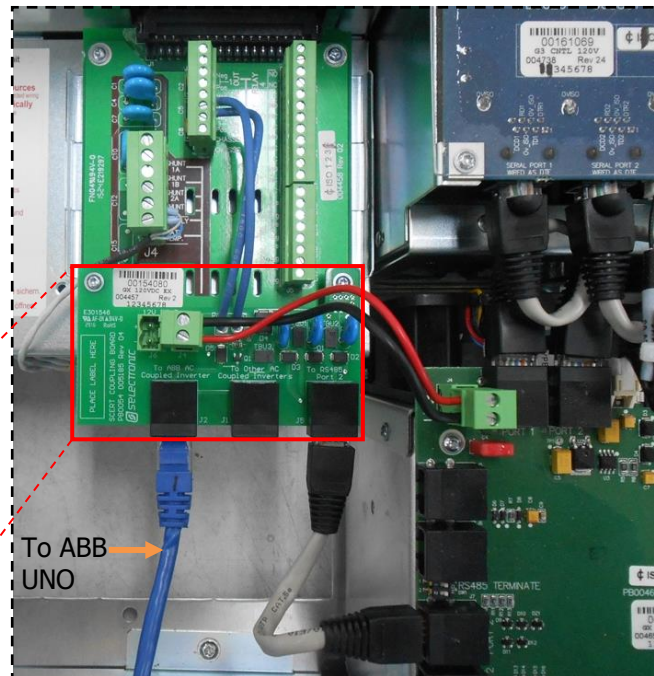
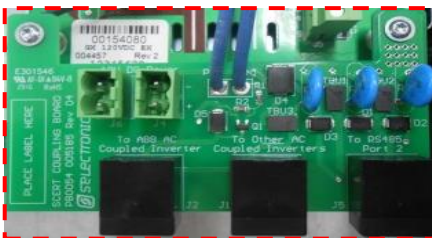

- Connect the RJ45 Connector lead from the AC Coupled Interface PCA "To RS485 Port 2" to the SP PRO Serial Communication PCA **RS485 Port 2**.
- Connect the second RJ45 lead from the AC Coupled Interface PCA "To ABB AC Coupled Inverter" to the ABB UNO **RS485** connector (see section "RS485 Connection to first ABB UNO").
- Connect the AC Coupled Interface PCA power loom (12V) from AC Coupled Interface PCA "12V DC Power J4" to the SP PRO Serial Communication PCA 12V connector.

**Note:** Do not connect any RJ45 leads to the AC Coupled Interface PCA "To Other AC Coupled Inverters" connector as the pin out is different to the ABB UNO connection.

# SP PRO ABB UNO Managed AC Coupling Installation Notes



## ABB UNO Communication link to SP PRO Communication Card

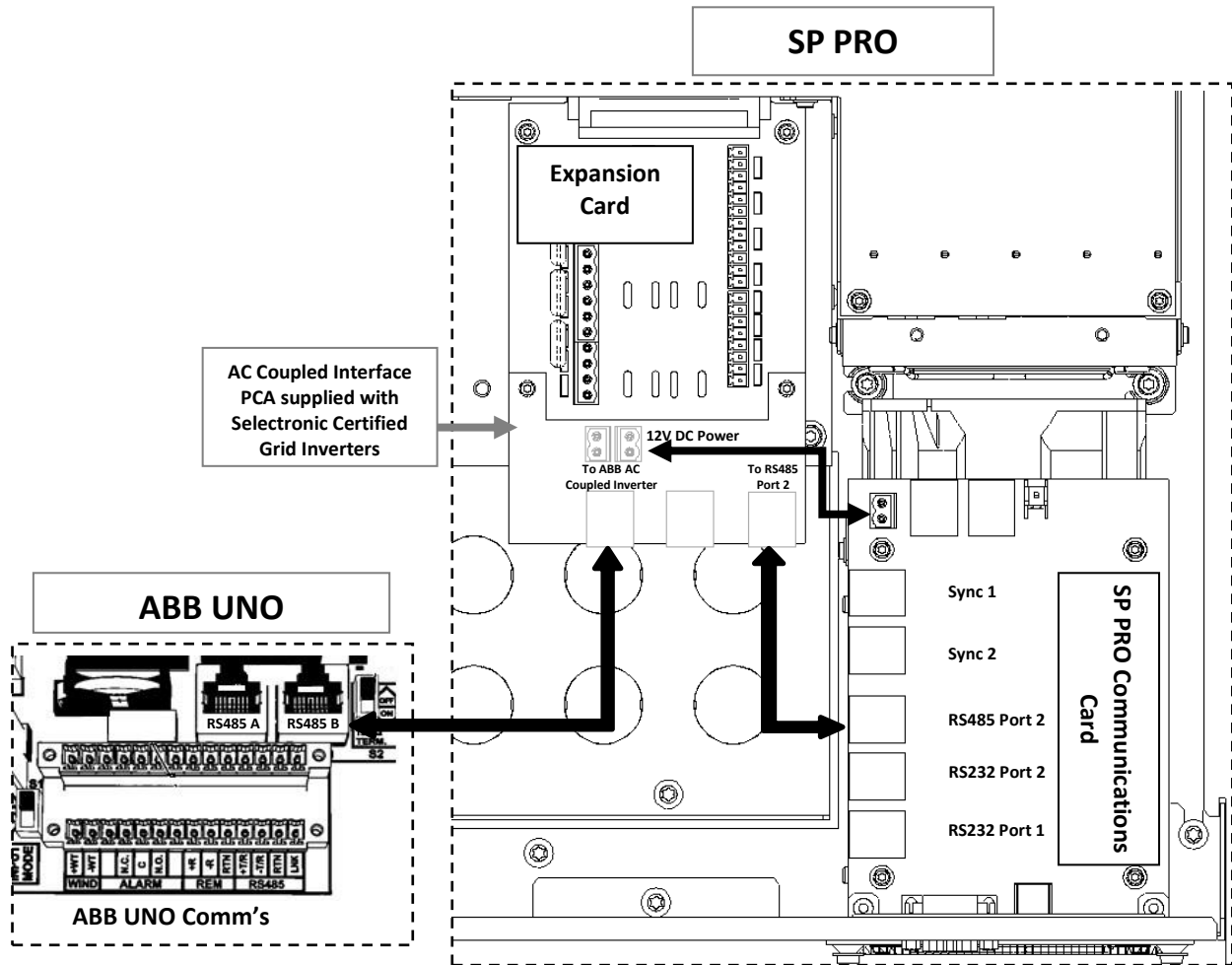

*SP PRO Connections (inside unit) – RS485 Port 2 RJ45 connector to AC Coupled Interface PCA (Sergio) and to ABB UNO RS485B connector*



# SP PRO ABB UNO Managed AC Coupling Installation Notes



## ABB PVI-3.0/3.6/4.2-TL-OUTD Series RS485 Connections



ABB PVI-3.0/3.6/4.2-TL-OUTD Series RS485 Connections (inside unit) – RJ45 connectors

On the ABB UNO there are two RJ45 sockets allowing “looping through” of the wiring to additional inverters. Either connection point is suitable.

When looped to another ABB UNO, the termination switch should be set to “OFF” (away from ON). For the last ABB UNO on the Communications Link (RS485) (or when only one ABB UNO is used), the termination switch must be set to “ON”.

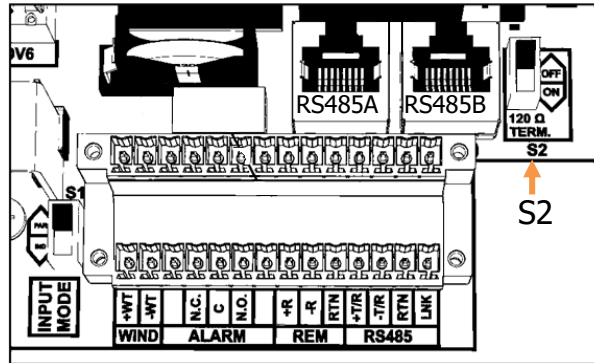
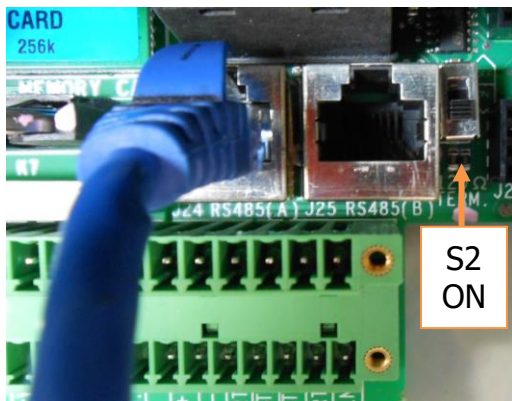

Last ABB on Communications Link (RS485), or when only ABB is used:  
S2 ON (Terminator ON)



ABB loop-through:  
S2 OFF (Terminator OFF)

# SP PRO ABB UNO Managed AC Coupling Installation Notes



## ABB PVI-5000/6000-TL-OUTD Series

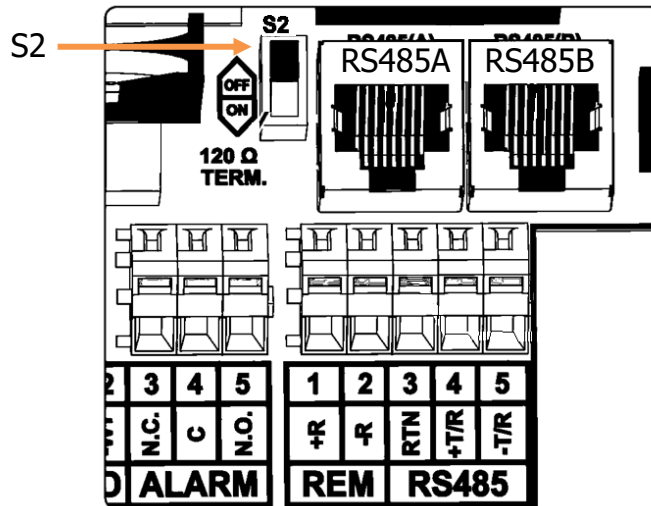

*ABB PVI-5000/6000-TL-OUTD Series RS485 Connections (inside unit) – RJ45 connectors*

On the ABB UNO there are two parallel sets of RJ45 connections allowing “looping through” of the wiring to additional inverters. Either connection point is suitable.

When looped to another ABB, the termination switch should be set to “OFF” (away from ON). For the last ABB UNO on the Communications Link (RS485) (or when only one ABB UNO is used), the termination switch must be set to “ON”.



Last ABB on Communications Link (RS485), or when only ABB is used:  
S2 ON (Terminator ON)



ABB loop-through:  
S2 OFF (Terminator OFF)

# SP PRO ABB UNO Managed AC Coupling Installation Notes



## Configuration – Additional Settings

It is recommended that the Site Configuration wizard in the Easy Start Guide (in SP LINK 8.0 and above) be used to configure the SP PRO settings. Using the wizard will ensure all the SP PRO settings are compatible with the managed AC coupled system.

The settings detailed below will be set when the Site Configuration Wizard is used to configure the SP PRO. Only the additional settings required to enable ABB Managed AC Coupling are shown. The remainder of systems settings will be set by the Site Configuration Wizard.

The SP PRO must be configured before any of the ABB UNOs are energised. The AC coupled failsafe system in the SP PRO is only enabled when the correct ABB configuration has been programmed into the SP PRO.

The ABB UNOs must be appropriately addressed to ensure correct communications (see “ABB Port Configuration” section).

## Settings That Are Set by Site Configuration Wizard

In SP LINK – CONFIGURATION SETTINGS – SYSTEM, the follow settings will be set:

- **Managed AC Coupled Link, String Inverter** is set to ABB Solar.
- **Number of ABB UNOs connected** is set to the number of ABB UNOs installed in the system.

Managed AC Coupled Solar

**Islanding Power Limit\***  
[0.1 - 15.0 kW]  
3.6 kW

AC Source Limit Monitor

**Monitoring Direction**  
Export

**Trip Power Limit**  
[0.0 - 250.0kW]  
50.00 kW

**Trip Time\***  
[0 - 1000 s]  
5

L1

**String Inverter\***  
ABB Solar

**Number of Devices\***  
[1 - 5]  
2

Fallback Power  
Disabled

SP LINK - Configuration Settings – System tab

### Note:

- Port 2 Communication settings will not be available once ABB Communication port has been enabled.
- The ABB UNOs numbering starts from 2 to 6 instead of 1 to 5 when creating a communication link to SP Link e.g. inverter 1 in SP Link is connected to ABB UNO address 2, inverter 2 in SP Link is connected to ABB UNO address 3 etc.

In the example used above, there are two ABB UNO connected to the SP PRO.

# SP PRO ABB UNO Managed AC Coupling Installation Notes



## ABB Port Configuration

The settings listed below are all that is required. Each ABB UNO must be set to an inverter address from 2 to 6 as appropriate.

**Note:** The ABB UNOs numbering starts from 2 to 6 instead of 1 to 5 when creating a communication link to SP Link e.g. inverter 1 in SP Link is connected to ABB UNO address 2, inverter 2 in SP Link is connected to ABB UNO address 3 etc.

1. Isolate the AC and connect the DC supply to the ABB UNO(s) and ensure that the DC supply (Minimum 200Vdc) is present at the ABB UNO.
2. When the ABB UNO is powered for the first time, select the "Nation" of installation. For Australia and New Zealand select "AS 4777" and press the **ENTER** key once and to save the setting, hold the ENTER key for 5 seconds, the ABB UNO will reset.



**Note:** When an ABB UNO is powered without the AC, "Missing Grid "will be displayed on screen.

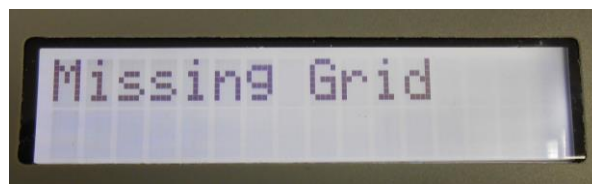

3. Once the display is active on the ABB UNO, enter parameter settings mode. To enter settings mode, press the **ESC** button to access the main menu, then using the **DOWN** key, scroll to Setting and press **ENTER**. The **ESC** is also used to escape back to the previous menu or to edit previous digits.

Use the **UP** and **DOWN** keys to scroll through the various menu items in settings. The menu is continuous. When the end is reached, the display automatically returns to the first item. The **UP/DOWN** keys are used to scroll menu options or to shift numerical scales in ascending/ descending order.

# SP PRO ABB UNO Managed AC Coupling Installation Notes



To access "Settings", a passcode is required. By default, **0000** is the passcode or by pressing the **ENTER** key four times to access the setting option. Use **ENTER** key to confirm an action or to access submenus.

19. Scroll to **Address** setting and press **ENTER**.

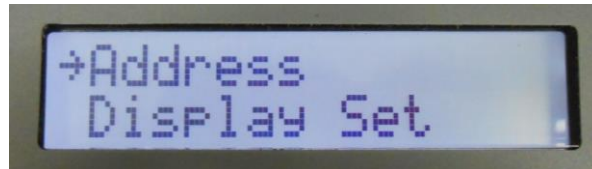

- a. If only one ABB UNO is installed then the address must be set to 2.
- b. If more than one ABB UNO is installed then the address must be allocated sequentially starting from 2 (i.e. first ABB = 2, second ABB = 3, third ABB = 4 etc).
- c. Once the "Address" is selected, press the **ENTER** key to configure and return to the "Setting" menu.

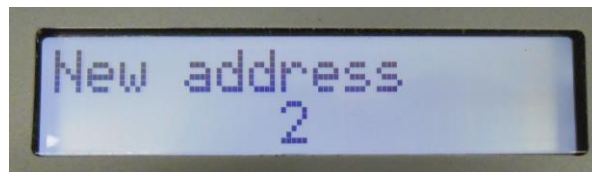

**Note:**

- a. The ABB UNO address starts from 2 to 6, where inverter 1 in SP Link is connected to ABB UNO Address 2, i.e. ABB UNO 1 address 2 = inverter 1 SP Link, ABB UNO 2 address 3 = inverter 2 SP Link, ABB UNO 3 address 4 = inverter 3 SP Link etc.
- b. Do Not skip any address numbers in the sequence when using multiple ABB UNOs.

20. Scroll to **Remote Control** setting and press **ENTER**.

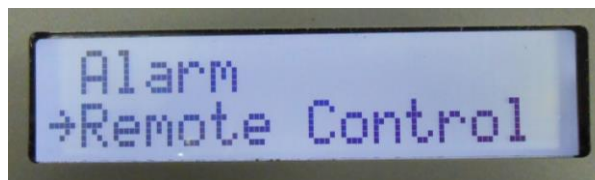

- a. Set the ABB UNO "Remote Control" to Enable, this will allow the ABB UNO to disconnect through the control signal.
- b. Once the "Remote Control" is enabled, press the **ENTER** key to configure and return to the "Setting" menu.

**Note:** The PVI-6000-TL-OUTD Remote Control setting contains an extra sub menu "Three Phase Unbalanced", when prompted, press the **ESC** key to return to Enable/Disable Remote Control and select Enable.

# SP PRO ABB UNO Managed AC Coupling Installation Notes



1. Scroll to the **Power Reduction** setting and press **ENTER**.

**Note:** ABB UNOs compliant with the AS/NZS 4777.2-2015 will **not contain** the Power Reduction setting in the inverter.



- a. The ABB UNO is set to 100% as default, use the **UP** key to set the "Power Reduction" to 0.0%.
- b. Once the "Remote Reduction" is selected, press the **ENTER** key to configure and return to the "Setting" menu.

**Note:** Do not go back into the Power Reduction setting once it is set to 0% otherwise the display will show 100% even though the setting was set to 0%. This is normal. The 0% can be verified by the commissioning test "Testing the Failsafe on the RS485 Link".

2. Press the ESC key once to return to the main menu. The ABB UNO may perform an automatic reset to configure the changes made.
3. If there are multiple ABB UNOs installed, repeat for all others.
4. When all is configured, the ABB UNO display screen will cycle through the main menu automatically. To stop the menu from cycling, press and hold the **ENTER** key until a lock appears at the top right-hand corner of the display screen.
  - a. To check that the ABB UNO is under power control, use the **DOWN** key to approach the following menu screen, make sure a percentage is displayed on the display indicating that the inverter is controlled by the SP PRO.



ABB UNO  
display locked

- b. The Percentage Power may be displaying less than 100% even though no power limiting is required. This is because the SP PRO intelligently uses predictive algorithms to determine the optimum value based on the available solar input to the grid inverter at that time.

Carry out the System Commissioning testing in **System Commissioning – Additional Tests**.

# SP PRO ABB UNO Managed AC Coupling Installation Notes



**Note:** If Reactive Power is required to be configured, perform the following procedure before step 6. Reactive Power must also be set in the SP PRO that is connected to the ABB UNO.

- a. Scroll to **Reactive Power** setting and press **ENTER**.

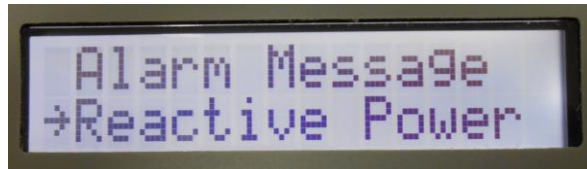

- b. The ABB UNO "Reactive Power" consists of four types of management to enable. Set the appropriate parameters required, press the **ENTER** key to configure and return to the "Setting" menu.



# SP PRO ABB UNO Managed AC Coupling Installation Notes



## System Commissioning – Additional Tests

In addition to the normal system testing that would be performed, the following additional tests must be performed as detailed below.

### Communications Link Verification

The correct operation of the ABB Managed AC Coupling relies on the Communications Link. It is vital that the communications link (RS485) connection has been setup correctly before operating the AC coupled system.

4. Check that all the RS485 connections have been connected correctly.
5. Isolate the AC and connect the DC supply to the ABB UNO. Make sure that the DC supply is present at the ABB UNO and its display is on.
6. Using SP LINK, connect to the SP PRO. In the Data View > Now tab there should be a model number displayed for each of the installed inverters.

|                       |                         |
|-----------------------|-------------------------|
| AC Solar #1 (PVI-3.0) | RS485 Device Address: 2 |
| AC Energy Today       | Not Applicable          |
| AC Power              | 0.00 kW                 |
| AC Volts              | 0.0 V                   |
| AC Current            | Not Applicable          |
| DC Power              | Not Applicable          |
| DC Volts              | 225.3 V                 |
| DC Current            | Not Applicable          |
| Temperature           | 32 °C                   |
| AC Power Peak Today   | 0.00 kW                 |

The communication link may be further tested using the AC Solar Link Test found in SP LINK under the Service Settings tab.

3. In the Service Settings tab click the "Reset Counters" button.
4. Wait 2 minutes and check that the error count remains at zero for all the connected ABB UNOs. (An error count of 3 or less per minute is acceptable but in this case, it is good practice to check the wiring and that the termination resistors are set correctly in the SP PRO and ABB UNO.

Once the Communications link has been verified for each ABB UNO, the AC feeds to each ABB UNO can be switched on and full system testing and verification can be performed.

AC Solar Link Test  
Errors or non-responses from grid-tie inverters can indicate quality of link.  
Counting while grid tie inverter is off is normal.

|         |   |
|---------|---|
| Link #1 | 0 |
| Link #2 | 0 |
| Link #3 |   |
| Link #4 |   |
| Link #5 |   |

Reset Counters

### Testing the failsafe on the RS485 Link

Once the system is operational, unplug the RS485 communications link from the SP PRO to the ABB UNOs. Wait 1 minute and check that the output of each of the ABB UNOs has dropped to approximately 0.1kW.



# SP PRO ABB UNO Managed AC Coupling Installation Notes



## Appendix III: Communications Link Configuration for ABB DM PLUS with "AC Coupled Interface PCA"

The communication link always starts at the SP PRO and links to the "AC Coupled Interface PCA", then connects to all the ABB UNOs in a daisy chain arrangement and finishes at the last ABB UNO. The ABB UNO link is used to connect subsequent ABB UNOs ON the same phase as the SP PRO. Do Not Connect ABB UNOs on different phases together.

To install the AC Coupled Interface PCA, remove the bottom two screws from the Expansion Card and replace them with the provided 2x standoffs. Then mount the AC Coupled Interface PCA to the Expansion Card inside the SP PRO close to the Serial Communication PCA as illustrated.

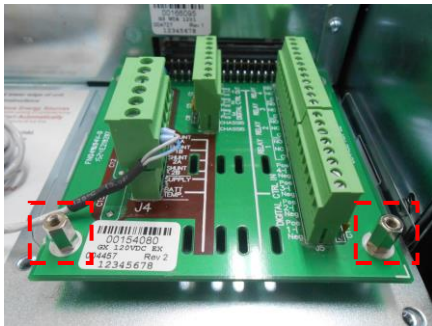

Expansion Card bottom screws replaced with stand offs.

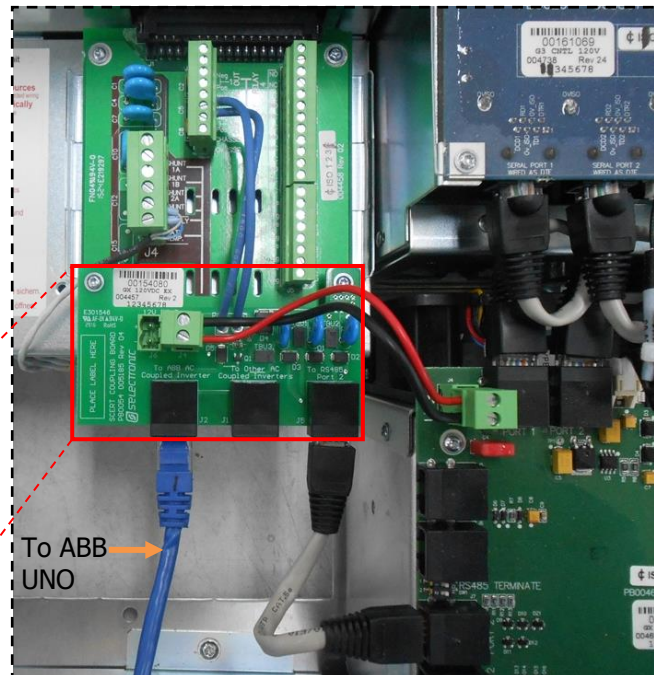
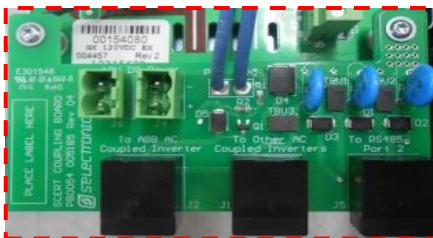

- Connect the RJ45 Connector lead from the AC Coupled Interface PCA "To RS485 Port 2" to the SP PRO Serial Communication PCA **RS485 Port 2**.
- Connect the second RJ45 lead from the AC Coupled Interface PCA "To ABB AC Coupled Inverter" to the ABB UNO **RS485** connector (see section "RS485 Connection to first ABB UNO").
- Connect the AC Coupled Interface PCA power loom (12V) from AC Coupled Interface PCA "**12V DC Power J4**" to the SP PRO Serial Communication PCA 12V connector.

**Note:** Do not connect any RJ45 leads to the AC Coupled Interface PCA "To Other AC Coupled Inverters" connector as the pin out is different to the ABB UNO connection.

# SP PRO ABB UNO Managed AC Coupling Installation Notes



## ABB UNO Communication link to SP PRO Communication Card

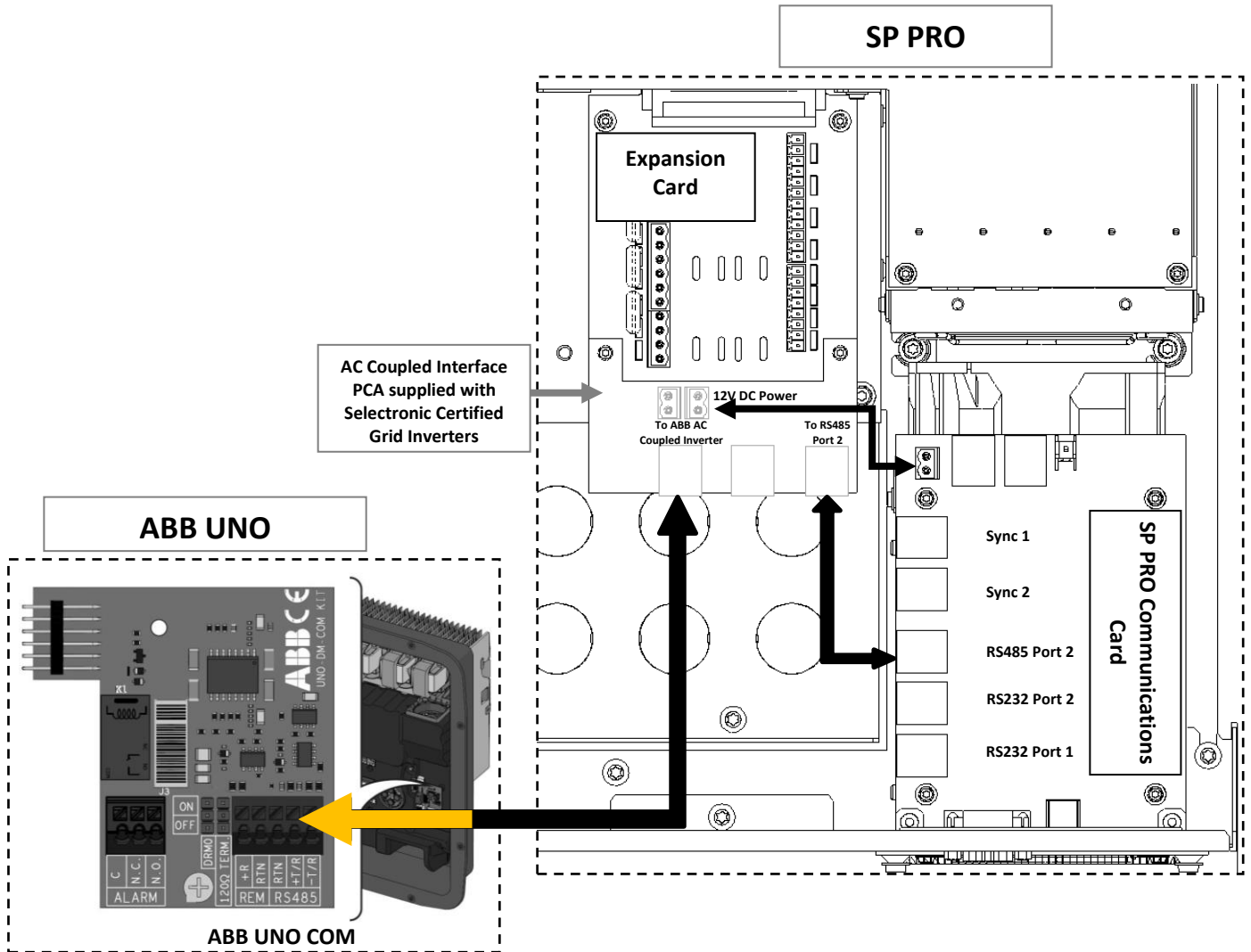

*SP PRO Connections (inside unit) – RS485 Port 2 RJ45 connector to AC Coupled Interface PCA and to ABB UNO RS485B connector*

# SP PRO ABB UNO Managed AC Coupling Installation Notes



## RS485 Connection to First ABB UNO

Using the supplied 'CAT5' network cable connect one end to the AC Coupled Interface PCA "To ABB AC Coupled Inverter" on the SP PRO. At ABB UNO 01 (Address# 02), **cut off the non-connected RJ45 connector**, expose and crimp the wires using wire crimps or alternatively use a longer cable as required (not supplied) as outlined in the table below.

**Note:** For wireless RS485 communication (Order code: 005316) please refer to Appendix I.

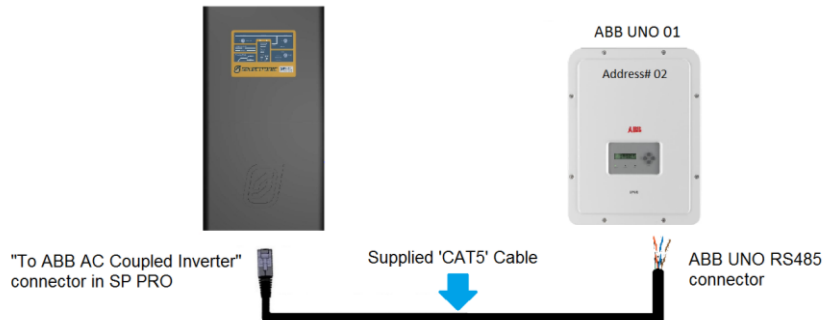

**Please Note:** There are two different colour coding for RJ45 plugs, **T568A** and **T568B**, it is common that either colour code is used. To ensure correct connections please check that the "RS485 RJ45 Adaptor pin #" (see below table) corresponds to the "ABB UNO RS485 Connection" by buzzing out the lead before connecting it to the ABB UNO or the SP PRO.

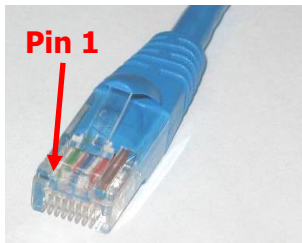

RS485 RJ45 Adaptor Pin 1 designation

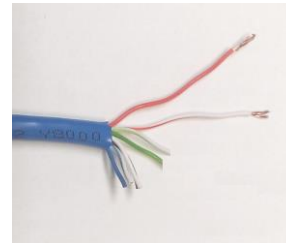

Cut off one RJ45 Connector

| RS485 RJ45 Adaptor pin # | Signal      | T568A colour code | T568B colour code | ABB UNO RS485 Connection |
|--------------------------|-------------|-------------------|-------------------|--------------------------|
| 1                        | GND         | Green/White       | Orange/White      |                          |
| 2                        | GND         | Green             | Orange            |                          |
| 3                        | RS485 - B   | Orange/White      | Green/White       | +T/R (RS485)             |
| 4                        | GND         | Blue              | Blue              |                          |
| 5                        | RS485 - A   | Blue/White        | Blue/White        | -T/R (RS485)             |
| 6                        | GND         | Orange            | Green             |                          |
| 7                        | RS485 - RTN | Brown/White       | Brown/White       | RTN (RS485)              |
| 8                        | GND         | Brown             | Brown             |                          |

Table 4: RS485 adaptor to ABB UNO connections and wire colours

# SP PRO ABB UNO Managed AC Coupling Installation Notes



Connect the three wires from the CAT5 network cable to the ABB UNO connector, +T/R, -T/R and RTN. The RS485 terminals are located on the right-hand side edge of the connector as illustrated.

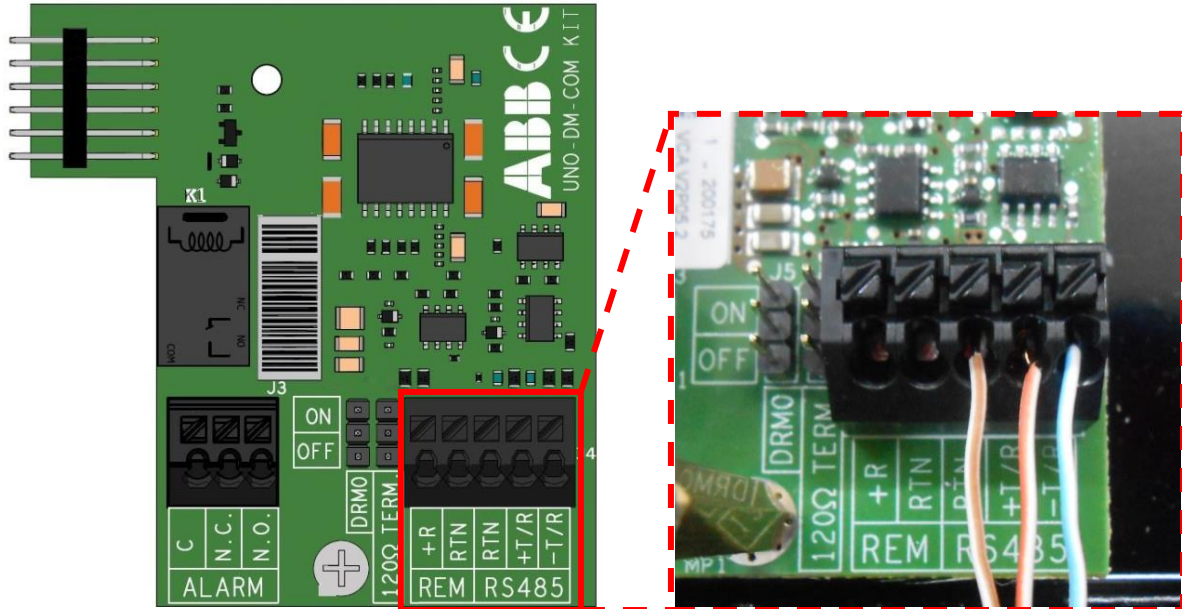

*Connection of AC Coupled Interface PCA "To ABB AC Coupled Inverter" to ABB UNO RS485 connector, colour code T568A is shown above.*

**Note:** Only the wires connected to the RS485 are used in ABB UNO.

The last ABB UNO of the daisy chain must be terminated provided jumper at the pins marked "120Ω TERM." must be placed in the ON position as shown.

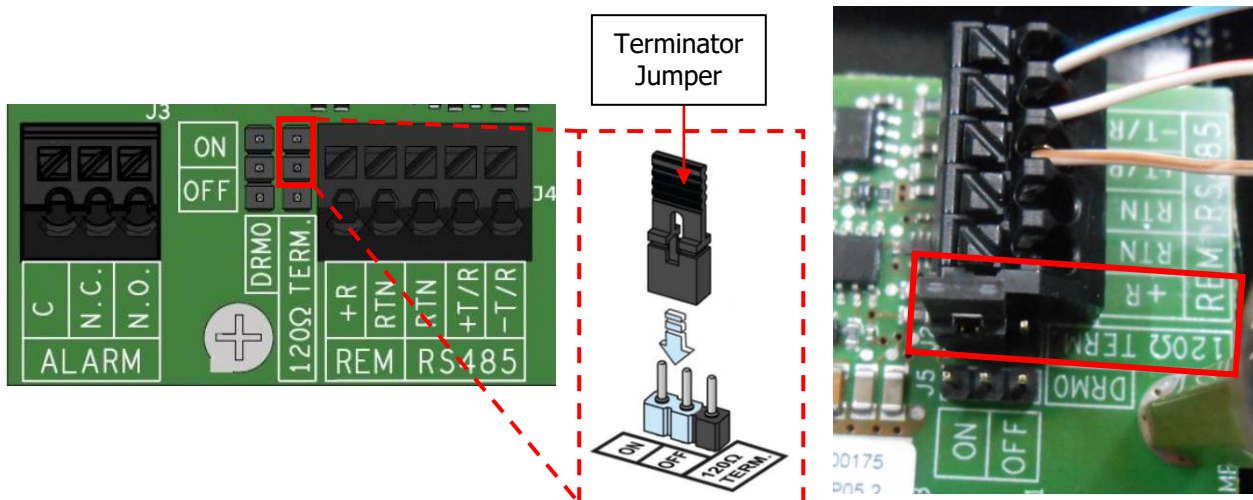

**Note:** When connecting multiple ABB UNOs together, the terminating jumper must be set to OFF "120Ω TERM." for all ABB UNO except the last inverter of the daisy chain (ON).

# SP PRO ABB UNO Managed AC Coupling Installation Notes



## Connecting ABB UNO link between Inverters 02 (Address# 03) to 05 (Address# 06)

The following configuration outlines the connection for multiple ABB UNOs to the first ABB UNO (ABB UNO 01). If only a single ABB UNO is installed, skip to the next section (CONFIGURATION – ADDITIONAL SETTINGS).

Inside the ABB UNO there is an "RS485" black terminal block. The ABB UNO RS485 is designed to interface with multiple ABB UNOs in a daisy chain arrangement as shown below. When looping an ABB UNO to another ABB UNO, the termination jumper must be set to "OFF" (away from ON). For the last ABB UNO, the termination jumper must be set to "ON".

